

Science Meets Innovation.

World-class MBL sensors, wireless data loggers, and smart lab interfaces — now available in India with complete turnkey support, INR pricing, and local service through Nvis Technologies.

About Nvis

India's Trusted Lab Solutions Partner

Founded in 2004, Nvis Technologies Pvt. Ltd. is a renowned leader in providing hands on laboratory solutions for the Education sector, with a strong global footprint across **75+ countries**

Part of the Sciencetech Group and head quartered in Indore, Nvis designs and manufactures didactic solutions for Physics, Electrical, STEM, Robotics, Clean Energy, and more — serving schools, polytechnics, engineering colleges, and universities. As the Authorized Distributor of Korea Digital's ScienceCube products in India, Nvis brings local procurement, service support, GST compliant invoicing, and end-to-end lab setup expertise to every institution.

STEM Labs | 75+ Countries | Since 2004

Turnkey Setup | Indian Warranty

About ScienceCube

Korea's Leading MBL Science Platform

ScienceCube by Korea Digital Co. Ltd. is a comprehensive **Microcomputer-Based Lab (MBL)** ecosystem trusted by educators worldwide. From wireless Bluetooth sensors to all in one data loggers, ScienceCube empowers real-time, data driven experimentation.

The 2025 catalogue introduces new wireless sensors across Physics, Chemistry, Biology, and Earth Science including temperature, pH, CO₂, magnetic field, EKG, force, dissolved oxygen, and more alongside the powerful MAX-A2 all-in-one tablet interface.

Powered by the free Science app (Android & iOS), ScienceCube supports automatic experiment configuration, live graphing, report writing, and teacher-student network sharing.

30+ Wireless Sensors | BLE 5.0

Android & IOS | Free App | Max A2 Interface

Complete Lab Solutions for Every Level of Education



Schools

CBSE & ICSE science labs with ready experiment kits for Physics, Chemistry & Biology



Science Colleges

Advanced MBL setups for BSc labs — real-time data logging, wireless sensors



Engineering & Polytechnics

Dynamics systems, oscilloscopes, and sensor suites for applied science labs



Research & Universities

University-grade packages for Earth Science, Human Physiology & Water Quality

Content

1. Company Overview	▶	2~3
2. New Product		
– Data Logger for MBL (MAX-A2)	▶	4~5
3. Wireless Sensor (Bluetooth sensor)	▶	6~15
4. Data Logger for MBL (ScienceCube Pro)	▶	6~15
5. Data Logger for MBL (Free Linker2)	▶	16~17
6. Data Logging Program	▶	18~21
7. Science Cube Package	▶	22~24
8. MBL sensor	▶	25~39
9. Quick USB sensor	▶	40~42
10. Lab. Equipment	▶	43~47
11. MBL Products Package List	▶	48

All in One type Interface!

Acquisition	Sampling rate Max. 500 KHz (sweep mode only) Analog input 4Ch, Digital I/O 1Ch
Analysis	Calculating formulas to drawing graphs by touching the icon.
Result & Report	Students can write a report which is made for a subject of experiment.
High Performance	10.5" Big screen 2.0 GHz Octa-core



■ Features & Benefits

- MBL interface and smart device consist of one, so you can make an experiment more easily and quickly.
- Science#™ logging program is built-in(pre-install), it enables experimentation, analysis and report by using various built-in contents.
- Enables more efficient laboratory operation by utilizing experiment and report sharing through the network.



- You can make an experiment by connecting various sensors of ScienceCube® using 4 channels of sensor ports and 1 channel of digital in/out ports.
- It is a perfect ICT device for educational environments, because it supports network enabling teacher to monitor student.



■ Logging Application

- Analysis base on Contents.
- A variety contents for Physics, Chemistry, Biology and Earth Science.
- Experiment environment Auto-configuration.

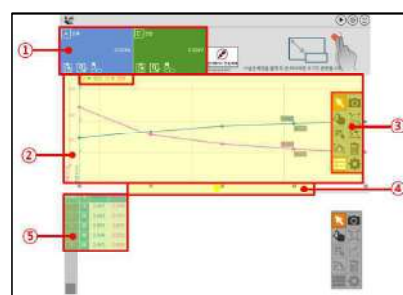
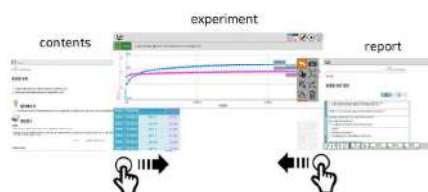

It is possible to connect all ScienceCube® interface and data logger.



■ Technical data
Performance

Display	
Size	10.5" + 10 point Capacitive Touch
Resolution	1920 * 1280 FHD
Processor	
Main-Application	2.0 GHz Octa Core CPU
Sub-Acquisition	120MHz, 32bit MCU
Storage	
RAM	4GB
Flash Memory	64GB
Expandable(Optional)	MicroSD (factory built-in)
Operating System	Android 12
Video Camera	5M Pixel(Rear) 2M Pixel(Front)
Connectivity	Wi-Fi 802.11b/g/n/ac@2.4G+5GHz Bluetooth 5.0
Audio	Internal Speaker * 2 Internal Microphone * 1 Audio Output * 1 MIC. input * 1
Additional Function	FM Radio GPS

Datalogging

Measurement	
Real time	1,000 Samples/s.
Sweep mode	Max. 500,000 Samples/s
AD Resolution	12bit
Sensor Ports	
Analog & Digital	4 channels
Digital I/O & Sensor	1 channel
Built-in Sensors	3-axis Accelerometer 3-axis Gyroscope Sound

General

Power Requirements	
USB Type-C	DC 5V, 2.0A
Rechargeable Battery	
Main System	Li-Polymer 5,300mAh
Sub System	2,000mAh or 4,000mAh (*Optional)
Environment	
Operating	0 .. 40°C
Storage	-40 .. 60°C

Mechanics

Dimensions	294 x 193 x 50mm (W x L x H)
Weight	860g (30 oz)
Housing Materials	ABS + Rubber

Packaging & Accessories

Packaging Dimensions	380 x 285 x 85mm (W x L x H)
Packaging Weight	1.6 Kg (3.5 lb)
Packaging Materials	
Carton	Paper
Internal cushioning	PE-Foam
Include Cables	
Sensors	1394-6P plug (1.5m) * 4
USB Charging	USB Type A/C (0.8m) * 1
Charging USB Adaptor	* Optional (Varies by country)
Input	AC220V, 50/60Hz
Output	DC5V, 2.0A (USB type A)

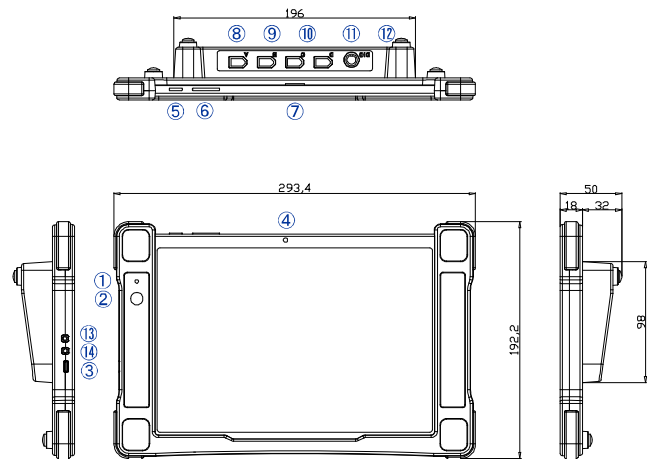
■ Functions

- ① INTERFACE STATUS LED
- ② INTERFACE POWER ON/OFF
- ③ POWER INPUT/CHARGE(USB-Type C)
- ④ FRONT CAMERA
- ⑤ MAIN POWER ON/OFF
- ⑥ SOUND VOLUME UP/DOWN
- ⑦ REAR CAMERA
- ⑧ ANALOG/DIGITAL SENSORS PORT [A]
- ⑨ ANALOG/DIGITAL SENSORS PORT [B]
- ⑩ ANALOG/DIGITAL SENSORS PORT [C]
- ⑪ ANALOG/DIGITAL SENSORS PORT [D]
- ⑫ DIGITAL I/O & SENSOR PORT
- ⑬ AUDIO OUTPUT
- ⑭ MIC. INPUT



NEW

Wireless Sensor



Checking data in real time through the display!

Power Button

Up to 4 sensors can be connected simultaneously, so you can use it easily in complex experiment environments.

Display : 0.96 (128*64)

Battery: Li-Polymer 700mAh

Wireless: BLE 5.0 & 2.1+EDR Dual Mode

Wired: USB-C type



DISPLAY



- ① Pairing mode
Mobile : BLE mode (Android, iOS)
PC : BT Classic mode (Windows)
* Press and hold the button when powering on to change the mode.
- ② Sensors ID paired with Bluetooth
- ③ Battery gauge & charge status
- ④ Measured value of the sensors

Wireless Stainless Steel Temperature WL100T

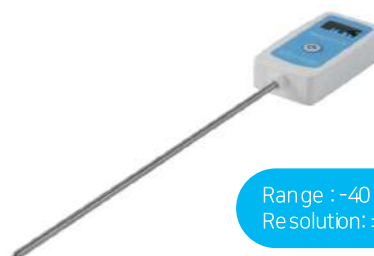

Range : -40 ~125°C
Resolution: ±0.0625 °C

"Wireless Temperature Sensor" measures the temperature of the gas or liquid. This sensor measures temperature by using temperature dependence of resistance. The sensing part is inserted into the stainless steel end of the thermometer so it is possible to measure the temperature more precisely because there is less error in the output process than the analog type of temperature sensors.

Experiment list
Principle of the mixture
Super cooling
Thermal equilibrium
Specific heat of metals
Radiation equilibrium

Wireless Voltage WL101V



Range : - 15~+15V
Resolution : 2mV

This wireless voltage sensor is a sensor that measures the difference in potential between two points on an electrical circuit. The voltage is displayed as a number on the LCD panel via an analog-to-digital conversion circuit. When using this Wireless Voltage Sensor to measure the voltage by decorating the electric circuit using various materials-such as dry cell, nichrome wire resistance, carbon resistance, LED, small bulb, etc.

Experiment list
Ohm's law (relationship between voltage and current)
Resistance according to sharp core length and cross section
Series, parallel connection of resistors
Voltage of solar cell

Wireless Current WL102C



Range : - 3.0~+3.0 A
Resolution: 1mA

The measuring principle of this "Wireless Current Sensor" is that a wire with a unique resistance value is measured using a voltage proportional to the current according to Ohm's law. It can be used for Ohm's law experiment with voltage sensor or for magnetic resistance test of electric resistance or current and since it is a wireless sensor, no connecting cable is needed.

Experiment list
Ohm's law (relationship between voltage and current)
Charge and discharge of battery
Making a coin battery
Resistance depending on the length and cross-sectional area of the sharp core

Wireless Gas Pressure

WL103P



Range : -1000~+3000hPa
Resolution: 0.6 hPa

“Wireless gas pressure sensor” measures relative values to ambient pressure. When measuring pressure, it converts to an intermediate form, such as a displacement, which converts the displacement into an electrical output, such as a voltage or current. This wireless sensor does not require a separate cable so that can be used easily in complex experiment environments. Also, it is possible to connect up to 4 sensors at same time, so you can use it with other kinds of sensors together.

Experiment list

Boyle's Law
Cloud creation principle
Reaction rate according to acid concentration
Solubility of Gas with Temperature

Wireless pH

WL104PH



Range : 0~14 pH
Resolution: 0,001 pH

“Wireless pH sensor” is a sensor that measures hydrogen ion concentration. It is a principle to determine the pH value from the potential difference between the glass electrode and the reference electrode with two standard solutions that know the pH value. The Science Cube Wireless pH Sensor does not require a separate connection cable, so it can be easily used in complex experimental environments such as monitoring pH change during neutralization of acid-base, chemical reaction and checking pH in a water tank during photosynthesis. You can use this sensor for investigation of acid rain and water quality as well.

Experiment list

Neutralization
PH measurement of various solutions

Wireless Force/Acceleration

WL105F



Force

Range : -80 ~+80N
Resolution: 0.01 N

Acceleration

Range : -16~+16g
Resolution: 0.01 g

“Wireless Force Sensor” measures the weight and force. Unlike conventional force sensors, it measures the force and the magnitude of the gravitational acceleration on each of the X, Y, and Z axes. It can be widely used for acceleration, shock, vibration and inclination measurement as well.

Experiment list

Hook's Law Friction
Irritation and reaction
Buoyancy
Impact and momentum

Wireless Motion

WL106M



Range : 0.15~6.0m
Resolution: 0,001m

The wireless motion sensor uses ultrasonic waves to measure the distance between objects.

Experiment list

Momentum and energy
Free Fall Experiment
Constant velocity linear motion
Laws of conservation of mechanical energy Pendulum movement

Wireless Conductivity

WL107EC



Range : 0 ~ 20,000 $\mu\text{S}/\text{cm}$
Resolution: 0.3 $\mu\text{S}/\text{cm}$

The wireless conductivity sensor can measure the conductivity of a solution or the total ion concentration of an aqueous sample. Conductivity measurement can directly infer the super ion concentration of the sample, even if the specific ion is unknown during the environmental test of the aqueous sample.

Experiment list

Significance of cell division
Electrolytes and non-electrolytes Neutralization reaction

Wireless Magnetic Field

WL108MG



Range : $\pm 50\text{G}$ / $\pm 500\text{G}$
Resolution: 0.015G / 1G

The wireless magnetic field sensor measures the strength of the magnetic field at the front of the sensor. The strength of the magnetic field in the solenoid coil, the Helm-Holtz coil, the experiment to prove Fleming's and Lorentz's law, etc., and the X, Y, Z axis measurement range (50G, 500G) can be easily changed.

Experiment list

Magnitude of magnetic field according to distance Find the N and S poles of a magnet
Magnetic field caused by electric current
Magnetic field according to the number of turns of the coil

Wireless Galvanometer

WL109GV



Range : -12.5 ~ +12.5 mA
Resolution: 0.001 mA

It is a sensor that can measure minute currents and has better resolution than wireless current sensors.

Experiment list

Bio current experiment Faraday's Law
Electrolyte and non-electrolyte experiments
electromagnetic induction

Wireless Smart Cart

WL110SC



Range
Force : $\pm 100\text{N}$
Speed : $\pm 3\text{ m/s}$
Acceleration : $\pm 16\text{ g}$
Gyro : $\pm 500^\circ/\text{s}$

Resolution
Force : 0.01N/0.1N
Distance : 0.5 mm
Acceleration : 0.001 g
Gyro : $0.1^\circ/\text{s}$

The wireless cart is a product specialized for dynamics-related experiments and the cart has built-in sensors such as distance, speed, acceleration, angular velocity and force, so you can perform various dynamics experiments.

Experiment list

Momentum and energy Impulse and momentum
The acceleration of the cart due to the fall of the weight.
Law of conservation of mechanical energy Constant velocity linear motion
Constant acceleration motion

Wireless CO₂ Gas

WL111CO₂



Range : 0 ~ 5,000 ppm
Resolution: 1ppm

The wireless CO₂ sensor can measure carbon dioxide in the air or in confined spaces such as botanical gardens and animal kennels. In addition, it is a sensor that can measure the amount of carbon dioxide produced by respiration of small creatures such as crickets by using an experimental tool such as an Erlenmeyer flask.

Experiment list

Yeast respiration photosynthesis
Respiratory rate as a function of temperature Metabolic rate of insects according to temperature Changes in citric acid and sodium bicarbonate

Wireless Light/Color/UV

WL112LC



Range: - Illuminance: 1 ~ 90,000 lux
Chromaticity: 1 to 65,535 counts
UV: 0 ~ 11 UV index
Resolution - Illuminance: 0.1 lux
Chromaticity: 1 count
UV: 0.1 UV index

The wireless Light/Color/UV sensor is a sensor that measures wavelengths from the visible light range to the ultraviolet range so that optics-related experiments can be carried out.

Experiment list

Light intensity according to distance photosynthesis
The brightness of the light bulb depending on the battery
light synthesis
Principle of sunscreen

Wireless Oxygen Gas

WL11302



Range : 0 ~ 25%
Resolution: 0.01%

The wireless oxygen sensor is a sensor that accurately measures the amount of oxygen in the air or in an enclosed space. The wide range enables any experiment or measurement, and can measure atmospheric air along with carbon dioxide.

Experiment list

photosynthesis
Plant oxygen

Wireless ORP

WLORP



Range : -450 ~ +1,100 mV
Resolution: 0.1mV

Wireless ORP sensor ORP sensor is a test device that measures the ratio of oxidation (loss of electrons) and reduction (gain of electrons) of dissolved substances in solution. The unit is mV, and it can be measured together with the pH value of a solution.

Experiment list

Measurement of redox degree
Transformation of Coke

Wireless Fine Particles

WL115PM



Range : 0 ~ 500 $\mu\text{m}/\text{m}^3$
Resolution: 1 $\mu\text{m}/\text{m}^3$

The wireless fine dust sensor can measure fine dust in the air and simultaneously measure fine dust (10 μm) and ultrafine dust (2.5 μm).

Experiment list

Measure whether fine dust is generated when using a gas stove
Measurement of fine dust in the air
Measuring the effect of air purifying plants
Measurement of fine dust according to location

Wireless B-Differential Gas Pressure

WL116P



Range : -650 ~ +650 hPa
Resolution: 0.355 hPa

Wireless pressure sensor B has a narrower range than pressure sensor A.

It can measure pressure more accurately, has excellent resolution and is used in chemical experiments where a small amount of gas is generated.

Experiment list

Decomposition of hydrogen peroxide
How clouds are formed
Reaction rate according to surface area

Wireless Temperature/Humidity

WL117H



Range : 0 ~ 100%
Resolution: 2%

Wireless temperature-humidity sensor is a sensor that can measure relative humidity and temperature at the same time. It outputs a voltage according to the relative humidity in the air and detects humidity by air circulation.

Experiment list

Measurement of evaporation rate according to humidity
Observation of optimal growth conditions by relative humidity in greenhouses, etc.
Comparison of static electricity generation according to humidity

Wireless Dissolved Oxygen

WL118DO



Range : 0 ~ 50 mg/L
Resolution: 1%

The wireless DO sensor is an optical dissolved oxygen sensor and is a wireless DO sensor for measuring dissolved oxygen in aqueous solution. Measured values are automatically compensated for temperature, barometric pressure and salinity

Experiment list

Photosynthesis of aquatic plants
Water quality measurement

Wireless salinity

WL119S



Range: 0 ~ 50 ppt
Resolution: 0.01 ppt

Experiment list

Measuring sea salt level
Measuring salinity by season

Wireless EKG

WL121E



Range: 0 ~ 5 mV
Resolution: 5 μ V

Experiment list

ECG measurement
Stimulus and response
Comparing visual, auditory and tactile response times

Wireless Spirometer

WL122SP



Range: -5 ~ +5 L/s
Resolution:

Experiment list

Spirometry
Lung function test

Wireless Thermocouple

WL123TC



Range: -200 ~ 1200°C
Resolution: 0.6°C

Experiment list

Flash point measurement
Temperature measurement for inner flame,
outer flame and flame core

Wireless Photogate

WL120PG



Gate width : 80 mm
Gate interval : 20 mm
Rise time : 2.5 μ s
Fall time : 3.8 μ s

Experiment list

Measuring the speed and acceleration of an object
Period measurement of simple pendulum motion
Time interval measurement of a moving object
Measurement of gravitational acceleration in free fall motion
Utilization of droplet coefficient in neutralization titration experiment

Wireless Sound Pressure

WL124S



Range : 40 ~ 120 dB
solution: 0.1dB

Experiment list

Decibel measurement
Sound barrier effect measurement
Why are the antennas round?

Wireless Weather

WL125W



Range
Temperature : -40 ~ 60 °C
Humidity : 0 ~ 100 %RH
Barometer : 300 ~ 1,100hPa
Wind Direction : 0 ~ 360°
Wind Speed : 0 ~ 30 m/s
Light : 0 ~ 188,000 Lx
UV : 0 ~ 10 Index

The wireless weather sensor is a multi-sensor that can measure various meteorological measurement with one sensor. Built-in display and wireless communication add portability and convenience.

Experiment list

weather observation during the day
Weather forecast through change of weather information in our village. Compare the weather in your current location with the local weather forecast.

Wireless Radiation

WL126R



Range: 0 ~20 mR/hr
0 ~ 20,000 CPM
Resolution: 1 CPM

Experiment list

Radioactivity measurement

Wireless Electrostatic Charge

WL127Q



Range : $\pm 5/\pm 20/\pm 100$ nC
Resolution : 0.05/0.01/0.003 nC

Experiment list

Measurement of charge by induction
Measurement of charge production and distribution
Measurement of charge on a capacitor

Wireless Colorimeter/Turbidity

WL128CT



Colorimeter
Range : 10 ~ 90 %T
Resolution : 0.1 %T

Turbidity
Range : 0 ~ 200 NTU
Resolution : 0.1 NTU

Experiment list

Understanding Beer's Law
Measure the concentration of the solution and observe the reaction time
Determine the correlation between concentration and time
Water quality analysis

Wireless Heart Rate

WL129HR



Range : 0 ~ 250 BPM
Resolution : 1 BPM

Experiment list

Compare the heart rate of different individuals
Monitor heart rate before, during, after exercise
Monitor the recovery rate after exercise.
Check a person's heart rate before and after eating

Wireless Drop Counter

WL130DC



Range : 10 drop/s
Resolution : 1 drop

Experiment list

Collect pH vs. volume data in a typical acid-base titration
Collect conductivity vs. volume data
Collect mV vs. volume data
Collect temperature vs. volume data

Wireless Energy

WL131J



Voltage Range : 0~36V
Current Range : 0~1.0A

Experiment list

Experiment with various renewable energy sources.
Determine the electrical energy generated from wind turbines or solar panels.
Investigate the effect of load on the output of wind turbines or solar panels.

Wireless Vertical Temperature

WL132T



Range : -40~125°C
Resolution : 0.1°C
Location : 4cm Interval

Experiment list

Measurement of vertical distribution of water temperature according to depth.
Temperature distribution according to height.
Observation of water convection phenomenon.

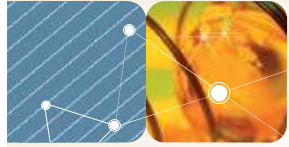

Data-Logger

Smart Learning & Smart Education

Interface

ScienceCube Pro

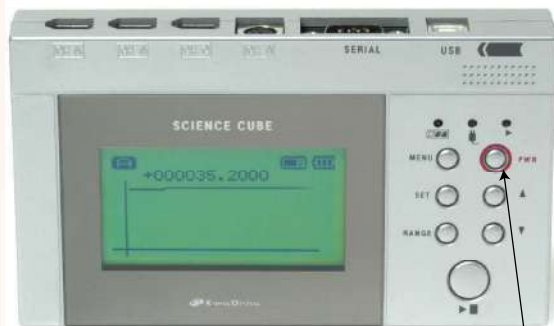

POWER

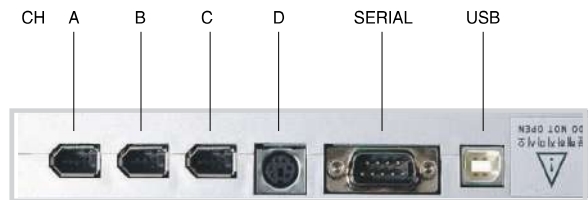

FEATURES

- Stand alone type of device- running without connection to the PC
- Portable-small & light feature
- No need to add special cards or drives. Automatically identifies the sensor.
- The Features menu on the LCD screen is composed with graphic User interface (GU) style icons can give you the easiest way.
- Various languages support. (English, Japanese, Chinese, French, Spanish, Arabic, Thailand, etc)
- As firmware updates, new sensors are produced or more functions are added newly. Science cube Pro will be automatically updated to fit on the newly produced sensors.

Size	160mmX90mmX25mm
Display	128X64 wide graphic mono screen
Data management	Up to 50,000 data collection and up to 16times experiment stores
Battery	Rechargeable lithium-polymer battery (1250mAh)
Sensor input	Using 3CH simultaneously. Real time mode 0.05sec/3CH 0.005sec/1CH
Sampling Time	Stan-alone mode 0.0001sec/1CH
Resolution	12bit A/D
Digital in /output port	1 channel
Output	PWM, Sine, Square, Triangle Sawtooth wave
Communication port	USB port, Serial port



Wireless Interface

NEW

Free Linker 2

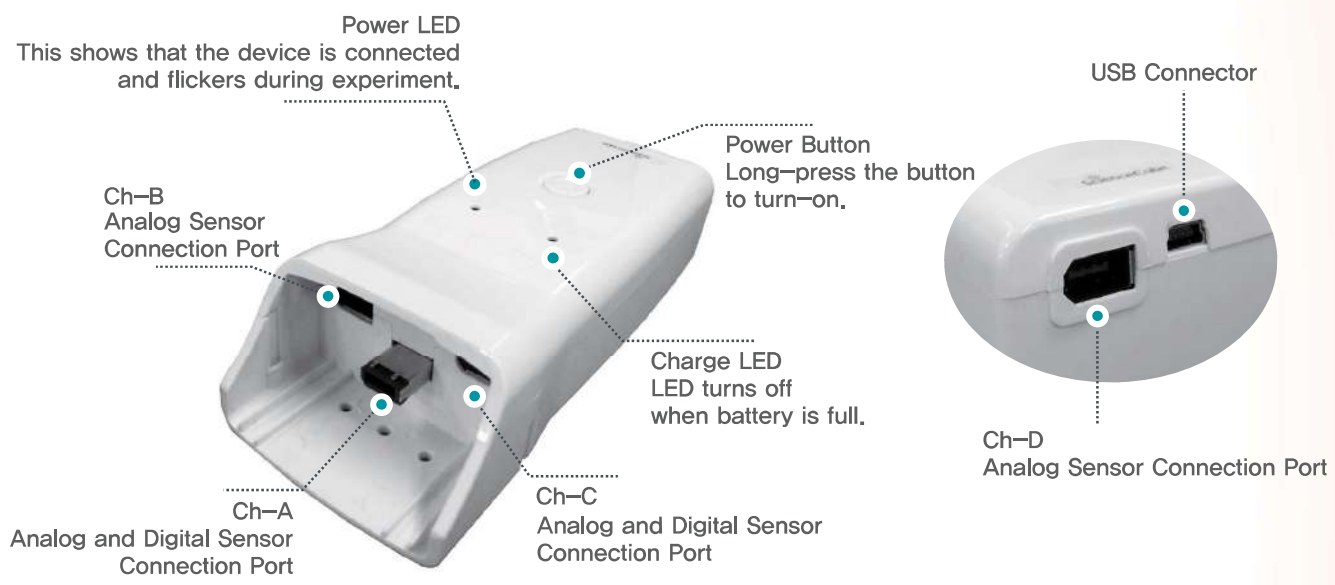

Free Linker 2 for MBL

Sensor input port	4 FREE CH (Analog & Digital)
Connections	Wireless (RF 2.4 GHz) / USB 2.0
Sampling Rate	MAX. 10 kHz / 1CH
Resolution	12 bit ADC
Battery	Li- polymer 2,000mAh
Charging Requirements	USB port (MAX. 500mA @5VDC)



Free download Data-Logging Program

Science# Program

* Analysis based on contents

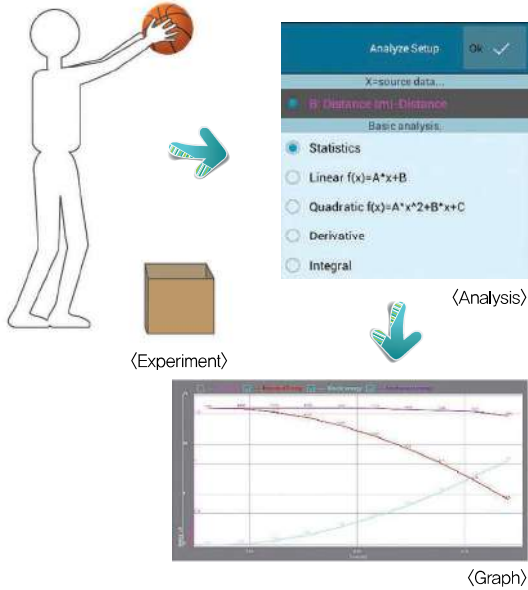

We have added physics formulas to a function of the formula menu. You will be able to do practically everything from calculating formulas to drawing graphs by touching the icon.

* ARCamera (Augmented Reality) Recording Function

When you record the experiment by camera using by Science#, you can see the sensor's name and value on the screen of Tablet PC at the same time so that you are able to get the efficient data. In addition, you can check the result and experimental condition and expect a high quality education.

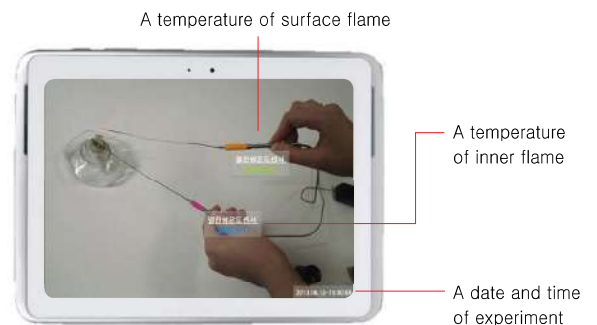

Science# shows results from sensors by detecting a color of Post-it.

Contents Authoring TOOL

Apply to Science# & Making contents on MS-Word

MS-Word



You are able to make contents by using Add-in function on MS-Word.

Science#



Students are able to share many contents that is made by other students or teachers through Science# contents Add-In function.

MS-Word



You are able to set up the experiment environment (Sensing gap, Measurement time, Data form) for data collecting in advance during contents making process.

NON-STOP



An experiment based on contents in Science#

You can use both contents in Science# and contents from the internet. Collecting and analyzing data in Logger.



Science# (Data Analysis Program) is working on **Windows and Android OS**.
 Windows OS (above Windows XP)
 All devices like PC, Laptop, Tablet PC except Windows Smart Phone
 Android OS (above 4.0 version)
 All devices like Smart Phone, Tablet PC



Making report

You can put the result of your experiment to a report by using the function of saving photographs and analysis data.

You can download "Science#" from Google Play Store.



Teacher Evaluation

You can send a report to your teacher by using data sharing function. Then your teacher can evaluate your report promptly.



Content List

Science# for

Science#



Push auto-configuration button on Science# contents. Then your experiment environment setting and data could be applied to Logger.

MS-Word



You can make a report for the result of an experiment. You can insert number-data input window or set up proper data form.

Science#



Students can write a report which is made for a subject of experiment. You can save a diversity type of experiment data as images. You also can write and register a learning concept by opening number or text input window.



Data-Logging Program

Science# for

Wireless Connection

You are able to connect Science# to an interface through wireless connection. Students are able to enhance their concentration level with Science# because they are free from cables.

Possible to use on any Android-based devices

You are able to use Science# by using an application which you are able to download on any Android-based devices.

Compatible with MBL, SMBL

Science# is a multi-functional Logger that can be used with all MBL and SMBL Sensors.

Contents Authoring TOOL is provided

We provide the best optimized content experiments, where end-users can help use the logger with Add-In function in MS-Word.



- It is possible to connect ALL ScienceCube's interface and Data Logger for MBL and SMBL.
- It supports all Windows OS above Windows XP except Windows RT, Windows CE
- All data is compatible with Science# for Android 2.0 and it is easy and simple to share and transfer the data between Android and Windows.
- Multi-Functional wireless connection
- A variety of contents for Physics, Chemistry, Biology and Earth Science
- Experiment Environment Auto-configuration
- Automatic computing mathematical formula based on contents
- Easy GUI
- Non-stop system for the reporting
- Contents Authorizing tool based on MS-Words

Excel Based Program **MBL & SMBL**

Now you can apply data-logging to excel program by installation ScienceCube® program in your computer simply. You can use Excel's powerful and easy function for making charts and graphs, controlling valuables, analyzing statistic. Also it's possible to work conversion, edition, sharing data. This program allows you make multi media report with Excel's original function.

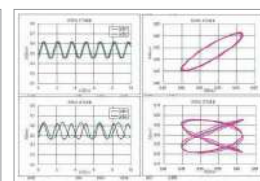
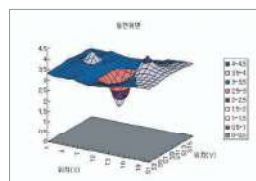
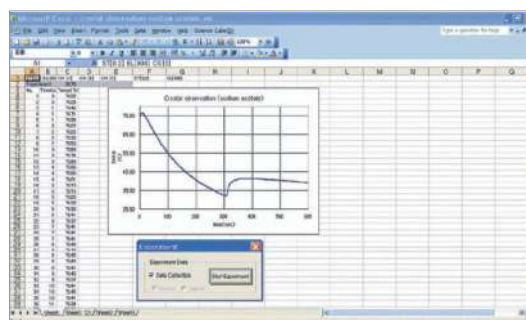

Free editing Excel Chart and graph

Easy data processing by using Excel's powerful function

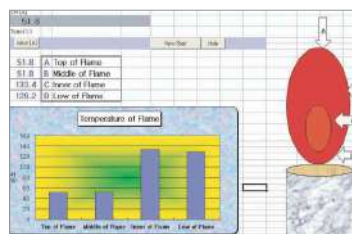

Ready-made experiment sheet with MACRO Function in Excel

Innovative Software Advantage of Excel based program

- **Simple operation :**
Beginner can learn how to operate the software without any trouble
- **Powerful procession function :**
Can record and analyze data at the real-time
- **Software's popularity :**
Can use to software as long as installing MS office program
- **Software's utility :**
to attract student's attention, user could use a vivid color in on's table and it would help to improve student's interest



Application Softwares

Sound Wave Program Android device

DESCRIPTION

SoundWave Trial (Free) app brings real-time sound data visualization and analysis using just the built-in sound sensor for guided inquiry-based learning and teaching to your Android phone or tablet. This is a trial preview only for educational purposes that it may be used to help students to practice measuring and analyzing sound or learn about scientific methods with experimental investigation of acoustical phenomena in musical dynamics such as loudness, pitch and timbre, and harmonic tones.

FEATURES

Measuring and analyzing sound of musical instruments or the human voice:

1. Measure sound data in real-time waveform and spectrum graph
2. Analyze audible sound data with fast and accurate digital audio signal processing for Android
3. View amplitude resultant in dB scale, search peak frequency and more.

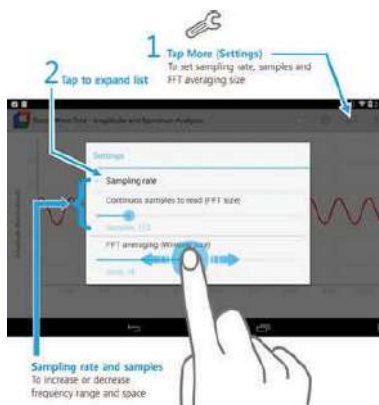
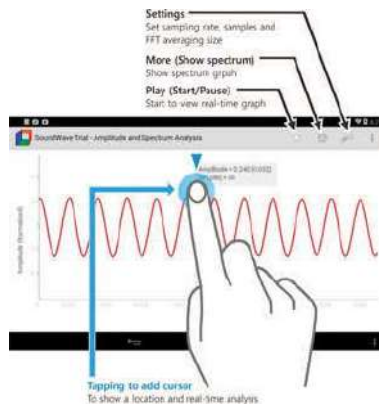

Video Contents Analyzer

Students can record movement of objects and analyze the data with VCA. This program makes it possible to chase and investigate the movement with tables and graphs. You can change any video files which you already recorded to our format file easily with this program. Input weight and dimension to calculate actual momentum, net force, kinetic energy, gravitational potential energy etc.

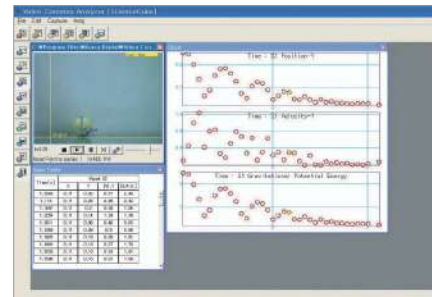

sound generation keyboard instrument

If you click Key board Instrument key, you can use the function. Click Start and experiment with keyboard. The red arrow shows the maximum frequency of peak frequency. This function is available in Sound Wave and Sound Spectrum. You can compare the frequency with other instruments. If Keyboard Instrument is used in Sound Generation, it shows sound wave according to the frequency of the key.

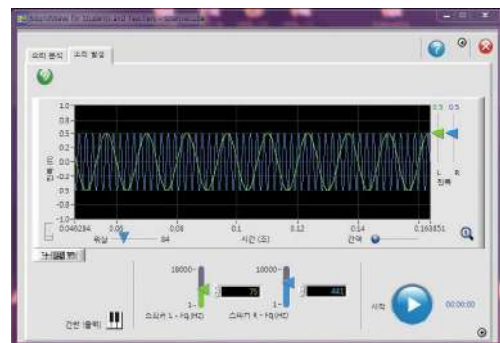

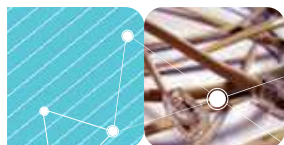

Science Cube Package

Well-organized ScienceCube package

UNIVERSAL PACKAGE

KDP-UP1000

Optional



	KDM-1002	Interface - Pro	Optional
	KDM-BLU02	Interface - Free Linker2	Optional
1	KDS-1002	Thermocouple Probe	V
2	KDS-1005	pH Sensor	V
3	KDS-1007	Magnetic Field Sensor	V
4	KDS-1008	Relative Humidity Sensor	V
5	KDS-1009	Differential Voltage Probe	V
6	KDS-1010	Current Probe	V
7	KDS-1012	Microphone	V
8	KDS-1013	Sound Level Meter	V
9	KDS-1014	Accelerometer 5g	V
10	KDS-1016	Barometer	V
11	KDS-1017	Turbidity Sensor	V
12	KDS-1020	CO ₂ Gas Sensor	V
13	KDS-1022	Dissolved Oxygen Probe	V
14	KDS-1023	Photogate	2
15	KDS-1029	Dual Range Force Sensor II	V
16	KDS-1031	Pt Temperature Probe	2
17	KDS-1032	Gas Pressure Sensor B	V
18	KDS-1033	Photodiode Light Sensor	V
19	KDS-1034	Gas Pressure Sensor A	V
20	KDS-1035	Galvanometer	V
21	KDS-1038	Conductivity Probe	V
22	KDS-1039	ORP Sensor	V
23	KDS-1040	EKG Set	V
24	KDS-1041	Video Capture Camera	V
25	KDS-1042	Motion Sensor II	V
26	KDS-1044	Colorimeter II	V
27	KDS-1046	Heart Rate Monitor	V
28	KDS-1047	Oxygen gas sensor	V
29	KDS-1051	Stethoscope	V
30	KDS-1053	Balance I (200g)	V
31	KDS-1057	Radiation Monitor II	V

AVAILABLE EXPERIMENT LIST

PHYSICS

- Motion Sensor : Free Falling Movement, Pendulum, Newton's law, Friction Force, Gravity, Collision and Conservation of Energy
- Current Sensor & Voltage Sensor : Ohm's law, Resistance in parallel circuit
- Galvanometer: Faraday's law
- Gas Pressure Sensor: Boyle's law
- Microphone: Sound beat, Sound waveform

CHEMISTRY

- Gas Pressure Sensor : Vapor pressure, The relationship between the boiling point and the pressure
- pH Sensor : Neutralization Titration reaction
- Pt Temperature Sensor : Exothermic reaction, Boiling & Freezing point, Specific heat

BIOLOGY

- Gas Pressure Sensor : Respiration of yeast, Transpiration
- CO₂ Gas Sensor : Photosynthesis
- Current Sensor & Voltage Sensor : Stimulus and Reaction

EARTH SCIENCE

- Pt Temperature Sensor : Convection current, Global warming, Making cloud
- Photodiode Light Sensor : Change of the light intensity by the distance
- Humidity Sensor : Range of daily humidity

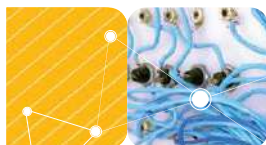

Package

PHYSICS

Optional



- Motion sensor : Measuring Gravity, Frictional Force, Pendulum movement, Uniform Motion, Measuring Acceleration
- Voltage & Current sensor : Ohm's law, making a battery with coins, making electrical circuits, resistance in Parallel/Serial Circuit
- Galvanometer : Faraday's law
- Gas pressure sensor : Boyle's law
- Microphone : sound beat, sound waveform

KDP-PH

		Standard	Advanced
	KDM-1002	Interface - Pro	
	KDM-BLU02	Interface - Free Linker2	
1	KDS-1007	Magnetic Field Sensor	V
2	KDS-1009	Differential Voltage Probe	2
3	KDS-1010	Current Probe	2 2
4	KDS-1012	Microphone	V V
5	KDS-1013	Sound Level Meter	V
6	KDS-1023	Photogate	2 2
7	KDS-1029	Force Sensor	V 2
8	KDS-1031	Pt Temperature Sensor	2 2
9	KDS-1034	Gas Pressure Sensor A	V V
10	KDS-1035	Galvanometer	V V
11	KDS-1041	Video Capture Camera	V V
12	KDS-1042	Motion Sensor II	V 2
13	KDS-1048	Accelerometer 25g	V

CHEMISTRY

Optional



- Gas Pressure Sensor B : Gas Development, Gas Dissolution, Vapor Pressure
- pH Sensor : Neutralization titration of Acid and Base
- Pt Temperature Sensor : Boiling & Freezing point, Specific heat
- Exothermic Rx & Endothermic Rx

KDP-CH

		Standard	Advanced
	KDM-1002	Interface - Pro	
	KDM-BLU02	Interface - Free Linker2	
1	KDS-1002	Thermocouple	V V
2	KDS-1005	pH Sensor	V V
3	KDS-1009	Differential Voltage Probe	V
4	KDS-1017	Turbidity Sensor	V
5	KDS-1020	CO ₂ Sensor	V V
6	KDS-1022	Dissolved Oxygen Sensor	V V
7	KDS-1031	Pt Temperature Sensor	2 2
8	KDS-1032	Gas Pressure Sensor B	V V
9	KDS-1035	Galvanometer	V V
10	KDS-1038	Conductivity Sensor	V V
11	KDS-1039	ORP Sensor	V
12	KDS-1044	Colorimeter II	V
13	KDS-1047	Oxygen Sensor	V V
14	KDS-1053	Balance I (200g)	V
15	KDS-1057	Radiation Monitor II	V
16		Micro Stirrer	V V

BIOLOGY

Optional



- Pt Temperature probe : Appropriate temperature for living
- Gas pressure sensor & CO₂ gas sensor : Photosynthesis, Yeast respiration
- Voltage & Current : Stimulus and Reaction
- Dissolved Oxygen Sensor : Measuring DO in water ecosystem

KDP-BY

		Standard	Advanced
	KDM-1002	Interface - Pro	
	KDM-BLU02	Interface - Free Linker2	
1	KDS-1008	Relative Humidity Sensor	V V
2	KDS-1020	CO ₂ Sensor	V V
3	KDS-1022	Dissolved Oxygen Sensor	V V
4	KDS-1031	Pt Temperature Sensor	2 2
5	KDS-1032	Gas Pressure Sensor B	V V
6	KDS-1033	Photodiode Light Sensor	V V
7	KDS-1035	Galvanometer	V V
8	KDS-1038	Conductivity Sensor	V V
9	KDS-1039	ORP Sensor	V
10	KDS-1040	EKG Sensor	V
11	KDS-1044	Colorimeter II	V
12	KDS-1046	Heart Rate Monitor	V
13	KDS-1047	Oxygen Sensor	V V
14	KDS-1051	Stethoscope	V



Package

EARTH SCIENCE

KDP-GE

Optional



- Pt temperature Sensor : Convection current, Global warming
- CO₂ Gas Sensor : Concentration of CO₂
- Dissolved Oxygen Sensor : Measuring DO in water ecosystem
- Photodiode Light Sensor : Brightness of stars, Change of the light intensity by the distance

		Standard	Advanced
	KDM-1002 Interface - Pro		
	KDM-BLU02 Interface - Free Linker2		
1	KDS-1005 pH Sensor	V	V
2	KDS-1008 Differential Voltage Probe	V	V
3	KDS-1012 Microphone	V	V
4	KDS-1013 Sound Level Meter		V
5	KDS-1016 Barometer	V	V
6	KDS-1017 Turbidity Sensor	V	V
7	KDS-1020 CO ₂ Sensor		V
8	KDS-1022 Dissolved Oxygen Sensor		V
9	KDS-1031 Pt Temperature Sensor	2	2
10	KDS-1033 Photodiode Light Sensor	V	V
11	KDS-1044 Colorimeter II	V	V
12	KDS-1047 Oxygen Sensor		V
13	KDS-1057 Radiation Monitor II		V

WATER QUALITY

KDP-WQ

Optional



- pH Sensor : Measuring acidity of liquids
- Pt Temperature sensor : Measuring temperature of liquids
- Turbidity : Turbidity of liquids
- Colorimeter : Measuring Chromaticity

		Standard	Advanced
	KDM-1002 Interface - Pro		
	KDM-BLU02 Interface - Free Linker2		
1	KDS-1005 pH Sensor		V
2	KDS-1009 Differential Voltage Probe		V
3	KDS-1017 Turbidity Sensor		V
4	KDS-1022 Dissolved Oxygen Sensor		V
5	KDS-1031 Pt Temperature Sensor		V
6	KDS-1038 Conductivity Sensor		V
7	KDS-1039 ORP Sensor		V
8	KDS-1044 Colorimeter II		V

HUMAN PHYSIOLOGY

KDP-HP

Optional



- Stethoscope & Heart Rate Monitor : Heart beat after exercise, sleep etc.
- O₂ & CO₂ Gas sensor : Human respiration

		Standard	Advanced
	KDM-1002 Interface - Pro		
	KDM-BLU02 Interface - Free Linker2		
1	KDS-1012 Microphone		V
2	KDS-1013 Sound Level Meter		V
3	KDS-1029 Force Sensor		V
4	KDS-1031 Pt Temperature Sensor		V
5	KDS-1032 Gas Pressure Sensor B		V
6	KDS-1037 High Concentration CO ₂ Sensor		V
7	KDS-1040 EKG Sensor		V
8	KDS-1041 Video Capture Camera		V
9	KDS-1042 Motion Sensor II		V
10	KDS-1046 Heart Rate Monitor		V
11	KDS-1047 Oxygen Sensor		V
12	KDS-1051 Stethoscope		V

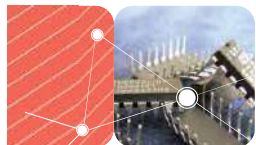

MBL Sensor

KDS-1014

Accelerometer 5g



- Full range : $-47\text{m/s}^2 \sim +47\text{m/s}^2$
- Available range : $-19.6\text{m/s}^2 \sim +19.6\text{m/s}^2$
- Resolution : 0.038m/s^2
- Frequency Response : $0\text{Hz} \sim 100\text{Hz}$

The Accelerometer 5g probe can be used for a wide variety of experiments both indoor and outdoor. The Accelerometer 5g probe measures acceleration along the line marked by the arrow on the sensor. Accelerations are measured in m/s^2 or g.

The Accelerometer 5g is affected by the gravity, and you can use this to calibrate probe. Also, it allows you to use the Accelerometer 5g as an Inclinometer to measure angles. When the position is changed from horizontal to vertical, its reading will change along with position $0\sim 90^\circ$. ($1\text{g} = 9.8\text{m/sec}^2$)

KDS-1048

Accelerometer 25g



- Full range : $-245\text{m/s}^2 \sim +245\text{m/s}^2$
- Available range : $-98\text{m/s}^2 \sim +98\text{m/s}^2$
- Resolution : 0.2m/s^2
- Frequency Response : $0\text{Hz} \sim 100\text{Hz}$

The Accelerometer 25g has more wide range than the Accelerometer 5g. It is good for studying one-dimensional collisions or any motion with larger accelerations. You can use Accelerometer for the experiments as measuring acceleration during collision, measuring acceleration as you swing the accelerometer in a vertical circle.

KDS-1053

Balance I



- Range : $0\text{g} \sim 200\text{g}$
- Resolution : 0.01g

KDS-1054

Balance II



- Range : $0\text{g} \sim 500\text{g}$
- Resolution : 0.1g

KDS-1061

Absolute Pressure Sensor



- Range : $0\text{hPa} \sim 6,900\text{hPa}$
- Resolution : 1.69hPa

Most experiments are based on Absolute pressure. The differential gas sensor (KDS-1032, KDS-1034) uses gauge pressure which converts standard 1atm to 0. But Absolute Pressure Sensor is designed to measure absolute pressure so can do precise experiment widely. Also, ScienceCube supplies Barometer (KDS-1016) which measures minute pressure changes.

KDS-1016

Barometer



- Range : $0\text{hPa} \sim 2,068\text{hPa}$
- Resolution : 0.6hPa

The Barometer (Atmospheric Pressure Sensor) is designed to study the weather. It measures changes in atmospheric pressure over long and short periods of time.

Accessories of Balance



Digital Balance is very easy to operate and useful for measure even minute change of weight. It helps students to do precise experiment especially in chemical subject. It is possible to use Studio-II and Excel program so user can input data of balance, when they conduct experiment.

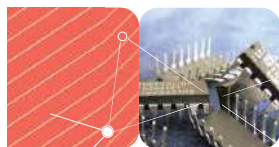

MBL Sensor

KDS-1020

CO₂ Gas Sensor



- Range : 0ppm ~ 5,000ppm (0 ~ 0.5%)
- Resolution : 2.44ppm
- Accuracy (at standard 1atm) :
±100ppm (0ppm ~ 1,000ppm)
±10% (1,000ppm ~ 5,000ppm)

The CO₂ Gas Sensor is used to monitor gaseous carbon dioxide levels in variety of biology and chemistry experiments. It measures in range of 0 to 5,000ppm by recording the amount of infrared radiation absorbed by CO₂

KDS-1038

Conductivity Probe



- Range:
Low Range : 0 ~ 200 μ S/cm
(0 ~ 100mg/L TDS)
Mid Range : 0 ~ 2000 μ S/cm
(0 ~ 1000mg/L TDS)
High Range : 0 ~ 20,000 μ S/cm
(0 ~ 10,000mg/L TDS)
- Resolution :
Low Range : 0.1 μ S/cm (0.05 mg/L TDS)
Mid Range : 1 μ S/cm (0.5 mg/L TDS)
High Range : 10 μ S/cm (5 mg/L TDS)

The Conductivity Probe can be used to measure either solution conductivity or total ion concentration of aqueous samples being investigated in the field or in the laboratory. Conductivity is one of the easiest environmental tests of aquatic samples.

KDS-1055

Salinity Sensor



- Range : 0ppt~50ppt
- Resolution : 0.02ppt

Salinity Sensor measures the total dissolved salt in water. Salinity is an important measurement for ecosystem in the water. It is possible to measure the salinity from pure water to salty ocean water with Salinity sensor. The normal salinity level in seawater is about 35ppt.

KDS-1037

High Concentration CO₂ Gas Sensor



- Range : 0% ~ 10% (0ppm ~ 100,000ppm)
- Resolution : 30ppm
- Accuracy (at standard 1atm) :
0ppm ~ 10,000ppm : ±100ppm or
±10% of reading,
10,000ppm ~ 20,000ppm : 20% of
reading
over 20,000ppm : qualitative only.
- Calibration Information :
- Slope : 25000ppm/V, offset 0V
(0V=0ppm, 4V=100,000ppm)

The High Concentration CO₂ sensor is used to monitor gaseous carbon dioxide levels in variety of biology and chemistry experiments as like inhaling capacity of germinating seeds and photosynthesis of plants.

EXPERIMENT-CO₂ GAS SENSOR

Photosynthesis and Respiration

Photosynthesis experiment Experiment method

- ① Prepare CO₂ sensor and interface.
- ② Insert enough plants into the Erlenmeyer flask and cover the entrance with a carbon dioxide sensor.
- ③ Run Science # (Sciencecube Dedicated Analysis Program) to connect the CO₂ sensor and interface and set up the experiment. [Recommended experiment setting ? data collection interval 1 second, experiment time 30 minutes]
- ④ Turn off the lights about 10cm and turn on the power.
- ⑤ After starting the experiment, observe the change of data.



RESULT - PHOTOSYNTHESIS

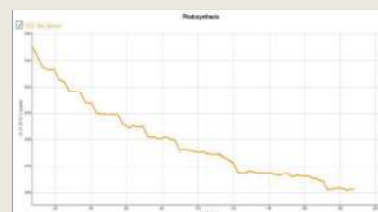

KDS-1044

Colorimeter II



- Range : 10 ~ 90%T
- Resolution : 0.035%T
- Wavelength : 430nm, 470nm, 565nm, 635nm

The Colorimeter II is designed to study the concentration of a solution by analyzing its color intensity. The Colorimeter II measures the amount of light transmitted through a sample at a wavelength which user selected. With the Colorimeter II, you can prove Beer's law. It has to be used with cuvette. ScienceCube® supplies 10 cuvettes with the Colorimeter II.

KDS-1070

Heart Rate Monitor (Ear Crip type)



- Range : 0BPM ~ 250BPM
- Resolution : 1 BPM

KDS-1010

Current Probe



- Range : DC $-1.2A \sim +1.2A$
- Resolution : 0.6mA
- Circuit Properties : Sensor is separated and insulated from ground
- Power Consumption : Max. 5W (0.01 Ω)

The Current Probe is designed for exploring the basic principles of electricity. Use the Current Probe to measure currents in low voltage AC and DC circuits. With a range of $\pm 1.2A$, this system is ideal for use in most "battery and bulb" circuits. Use it with the Differential Voltage Probe(KDS-1009) to explore Ohm's law, phase relationships in reactive components, and much more.

KDS-1035

Galvanometer



- Range : DC $-12.5mA \sim +12.5mA$,
 $-12.5mA \sim +12.5mA$,
 $-0.125mA \sim +0.125mA$
- Resolution : $6\mu A$, $0.6\mu A$, $0.06\mu A$,
- Circuit Properties :
Sensor is separated and insulated from ground

The Galvanometer is able to sense currents which are weaker than $\pm 12.5mA$. Range of usage can vary according to each experiment. The three ranges available are $\pm 12.5mA$, $\pm 1.25mA$, $\pm 0.125mA$. Galvanometer should be used in circuits with currents weaker than 12.5mA.

KDS-1009

Differential Voltage Probe



- Input voltage range : $-12.0V \sim +12.0V$
- Input Impedance (to ground) : $10M\Omega$
- Linearity : 0.01%
- Resolution : 3.1mV
- Supply voltage : 5V DC
- Supply current (typical) : 9mA
- Output voltage range : 0 ~ 5V

The Differential Voltage Probe is designed for exploring the basic principles of electricity. Use this probe to measure currents in low voltage AC and DC circuits. With a range $\pm 12V$, this system is ideal for use in "battery and bulb" circuits. Use it with the Current Probe (order code KDS-1010) to explore Ohm's law, phase relationships in reactive components and much more. This differs from the Voltage Probe that comes with your interface in that neither clip is connected to ground. Use multiple sensors to explore series and parallel circuits.

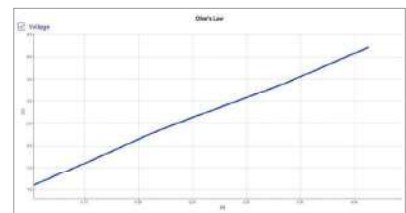

KDA-12

Square Cuvette



- Size : $45 \times 12.5 \times 12.5mm$
- Material : Plastic
- Quantity : 10pcs / 1set

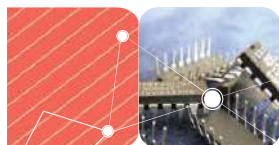

MBL Sensor

KDS-1022

Dissolved Oxygen Probe



- Range : 0 mg/L ~ 15 mg/L (or ppm)
- Accuracy : 0.3 mg/L
- Resolution : 0.004 mg/L
- Response Time : 95% of in 30 seconds, 98% of in 45 seconds
- Temperature Compensation : automatic at 5°C ~ 35°C

The DO(Dissolved Oxygen) Sensor can be used to measure the concentration of dissolved oxygen in water samples tested in the field or in the laboratory.

Since dissolved oxygen is one of the primary indicators of the quality of an aquatic environment, you can use the sensor to perform a wide variety of tests or experiments to determine changes in dissolved oxygen levels.

KDS-1029

Dual Range Force Sensor II



- Range : -10N ~ +10N / -80N ~ +80N
- Resolution : 0.0056 / 0.056
- Sensor Type : Electrical strain gage

Force Sensor II is measuring for the force of $\pm 10N$ or $\pm 80N$. It can be using by fixing with ring or moving cart. And it also could be used portable balance. It is for using to study about physical experiment as simple harmonic motion, collision, centripetal force.

KDS-1040

EKG (ECG) Set



- EKG
 - Range : 0mV ~ 5mV
 - Resolution : 5 μ V
- Pulse
 - Number of Pulse : 47BPM ~ 250BPM
 - Resolution : 1BPM

The EKG Sensor measures electrical signals produced during muscle contractions. ScienceCube® provides EKG Sensor and Electrodes as a set. It can be used for monitor EKG with various human activities. Also you can study the P, Q, R, S and T wave forms.

Ion Selective Electrode



The Ion Selective Electrode is a hand crafted PVC membrane ion-selective electrode which measures nitrate ions in aqueous solutions simply, quickly, economically, and accurately. They are used to conduct water quality studies. The ISE(Ion Selective Electrode) set consists of the FastFil Ion selective combination electrode, combining the Ion Selective electrode and the reference electrode, and ISE Probe amplifier.

Calcium Probe (Ca²⁺) **KDS-1064**

- Range : $5 \times 10^{-7}M$ ~ 1M
(0.02ppm ~ 40,000ppm)
- Resolution : 0.5mV

Ammonium Probe (NH₄⁺) **KDS-1065**

- Range : $5 \times 10^{-6}M$ ~ 1M
(0.1ppm ~ 18,000ppm)
- Resolution : 0.5mV

Nitrate Probe (NO₃⁻) **KDS-1066**

- Range : $5 \times 10^{-7}M$ ~ 1M
(0.1 ppm ~ 14,000ppm)
- Resolution : 0.5mV

Chloride Probe (Cl⁻) **KDS-1067**

- Range : $5 \times 10^{-6}M$ ~ 1M
(1.8 ppm ~ 35,000ppm)
- Resolution : 0.5mV

KDS-1043

Electrode Amplifier



Ion Selectivity Electrode Amplifier can be used with any electrode such as NH₄⁺, Cl⁻, Ca²⁺, Na⁺, K⁺, HNO₃⁻ etc. Also this amplifier can be connected to pH, ORP, TDS for handling signal. It is designed to amplify minute signal to available level with low noise, stability and reliability through ScienceCube's high technology.

KDS-1034

Gas Pressure Sensor A



- Range : $-1000\text{hPa} \sim -3000\text{hPa}$
- Resolution : 1.3hPa
- Unit : Differential (Relative) pressure
- Response Time : average 0.2ms

The Gas Pressure Sensor A is suitable for general gas pressure experiments like Boyle's law.

KDS-1032

Gas Pressure Sensor B



- Range : $-650\text{hPa} \sim +650\text{hPa}$
- Resolution : 0.335hPa
- Unit : Differential (Relative) pressure
- Response time : average 0.2ms

The Gas Pressure Sensor B is suitable for more precise biology experiments like respiration of yeast.

KDS-1046

Heart Rate Monitor



- Range : $0\text{BPM} \sim 250\text{BPM}$
- Resolution : 1BPM

The Heart Rate Monitor monitors a person's heart beat. This sensor monitors the electrical signal of the heart as like EKG sensor. This signal is measured by electrodes embedded in the chest belt of the Heart Rate Monitor. By graphing this signal, the heart rate can be determined.

KDS-1007

Magnetic Field Sensor



- Range : $-50\text{G} \sim +50\text{G}$ (5mT)
- Resolution : 0.024G
- Sensor depth : 5.0mm
- Sensor type : Radiometric, Linear Hall Effect Sensor
- Strobe Timing : changes according to interface (Max. 0.1ms)

The Magnetic Field Sensor can be applied for Fleming's Rule, Lorentz's Rule (electric magnet) experiment. Also it's used for various types of plant growth, action and magnetic field experiments.

KDS-1063

Magnetic Field Sensor II (with Scale)



- Range : $-50\text{G} \sim +50\text{G}$ (5mT)
- Resolution : 0.024G

Magnetic Field Sensor II has rod-shaped sensor so can measure magnetic field where Magnetic Field Sensor (KDS-1007) can't measure. Magnetic Field Sensor (KDS-1007) is appropriate for measuring surface and Magnetic Field Sensor II is ideal for narrow and long section. Especially the scale on the rod helps to acknowledge the distance visually.

It can be applied to measure magnetic field of Solenoid coil or Helmholtz coil, and prove Fleming's rule or Lorentz's formula.



KDS-1008

Relative Humidity Sensor



- Range : $0\%\text{RH} \sim 100\%\text{RH}$
- Resolution : $0.0375\%\text{RH}$

The Relative Humidity Sensor can be used to measure relative humidity in air as part of a weather station, transpiration rates of plants, greenhouse or terrarium.

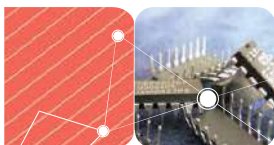

MBL Sensor

KDS-1023

Photogate



Internal Gate

- Infrared source peak wavelength : 880nm
- Rising time : 2.5uS
- Falling Time : 3.8uS

External Gate

- Infrared source peak wavelength : 880nm
- Spectrum Sensitivity : 500nm ~ 1050nm
- Rising time : 8uS
- Falling Time : 10uS

The ScienceCube® Photogate is a digital switch-type sensor that has two states low (ON condition) and high (OFF condition). The Photogate comprises an infrared transmitter and a receiver mounted and aligned in a plastic frame.

KDS-1012

Microphone



- Range : 20Hz ~ 20000Hz,
-50dbVrm ~ +20dbVrm

Microphone can measure FFT(Frequency Analyzing Spectrum), amplitude, vibration number, wave and utilized when studying beat, Doppler effect, making sounds, exploring sounds in everyday life, and instrument tuning.



KDS-1013

Sound Level Meter



- Accuracy : -1.5dB ~ +1.5dB
- Range : 35dB ~ 130dB

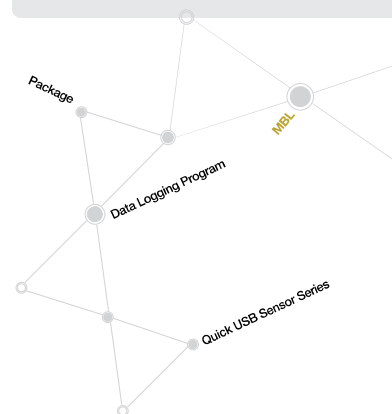

KDA-15

Pulley



- Effective circumference : 20cm
- Pulse/rotation : 10
- Effective diameter : 64mm
- Out diameter : 67mm

The Photo-event Pulley connects to the photogate by using the accessory rod that comes with the photogate. Place the rod through the hole in the photogate and move the pulley into position so that the rod can be threaded into it. Tighten up the rod so that the pulley is held firmly against the photogate. The Photo-event Pulley is a low-friction pulley with ten spokes.

KDS-1042

Motion Sensor II



- Range : 0.15 ~ 6m (Max. 10m)
- Resolution : 1 mm
- Gauging principle : Ultra Sonic Transducer
- Beam Angle : Cone, around 15°
- Sampling Rate : (Max. 100samples/s)
depends on measuring distance
- Application :
non-contact, measure distance to time
- Channels : [CH A] Channel
Channel A is used as the digital channel.

The Motion Sensor II is designed to detect object position by Ultra Sonic wave. You can do variety experiment with the Motion Sensor II as pendulum movement, free falling movement, etc.

KDS-1039

ORP Sensor



ORP Electrode

- Type : Sealed, gel-filled, epoxy body, Ag(AgCl) reference
- Storage solution : pH4 KCl solution (10g KCl in 100mL pH4 buffer solution)
- Temperature Range : 0°C ~ 60°C
- Impedance : ~20M Ω at 25°C

Electrode(ORP) Amplifier

- Amplifier input range :
-450mV ~ +1100mV
- Resolution : 0.5mV

The ORP sensor measures the ability of a solution to act as an oxidizing or reducing agent. ORP stands for Oxidation - Reduction Potential also known as Redox Potential.

KDS-1047

Oxygen Gas Sensor II

Long Life Time



- Range : 0% ~ 27%
- Output voltage range : 0V ~ 4V in air at 25°C sea level (standard) other range optional.
- Resolution : 0.01 %

The Oxygen Gas Sensor II measures the gaseous oxygen concentration in the range of 0 to 27%. It uses an electrochemical cell. The anode and cathode are immersed in an electrolyte. When oxygen molecules enter the cell, they get electrochemically reduced at the cathode. This electrochemical reaction generates a current that is proportional to the partial pressure of oxygen in the gas mixture. The current is measured across a resistance to generate a small voltage output. The voltage output is amplified to the 0 ~ 5V output range.

KDA-19

CO₂-O₂ Tee



This 'T'-shaped tube makes possible to experiment with CO₂ sensor and O₂ sensor simultaneously.

KDS-1071

Rotary Motion Sensor (Analog)



- Range : 0° ~ 360°(10 Turns)
- Resolution : 0.88°

Rotary motion sensor can indicate the data of the angle or turn' degree which are relative with the experiment of pendulum and turning in physics.

KDS-1073

Rotary Motion Sensor (Digital)



Rotary Sensor & Accessories are useful to study position and motion of objects. Students can investigate various phenomenon and laws as like Conservation of angular momentum, Oscillations of a pendulum, The rotational inertia of an aluminum disk, conservation of momentum etc.

KDA-16

Cart Picket Fence



Cart Picket Fence is to be used with Dynamics cart.

Size: 6.25*13 (cm)



KDA-17

Picket Fence



The Picket Fence is useful for free fall experiment with Photogate.

Size: 5,5*39 (cm)



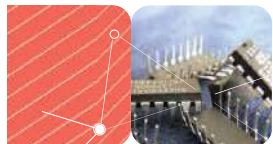

MBL Sensor

KDS-1033

Photodiode Light Sensor



- Full range : 0 lx ~ 15000 lx
General Purpose : 0 lx ~ 6000 lx
Sensitive range : 0 lx ~ 600 lx
- Resolution : adjusts according to range setting
- Spectral response range :
3300 Å (330nm) ~ 7200 Å (720nm)
- Peak spectral response : 5800 Å (580nm)

Photodiode Light sensor let students experiment various educational curriculum as like relations between luminosity and voltage, role of light in photosynthesis and transpiration.

KDS-1005

pH Sensor



- Range : pH 0 ~ 14
- Resolution : 0,0036 pH units

KDS-1077

UV Sensor



- Unit : mW/m^2
- Range : 0 ~ 1000 mW/m^2
- Resolution : 0,25 W/m^2
- Accuracy (Whichever is greater) : $\pm 5\%$, @25°C

EXPERIMENT-PHOTODIODE LIGHT SENSOR

Experiment method

- ① prepare the light sensor and interface.
- ② Align the distance between the flashlight and the illuminance sensor by 20cm.
- ③ Run Science # (Science Cube Dedicated Analysis Program) to connect the Ambient Light Sensor to the interface and set up the experiment. [Recommended Experiment Setting – Manual Collection]
- ④ Start the experiment and turn on the flashlight.
- ⑤ Collect illuminance value of 20cm and collect data while decreasing by 1cm.

3. pH measurement of various solutions

- ① Prepare the interface with pH sensor.
- ② Run the Science # (Sciencecube Dedicated Analysis Program) to connect the pH sensor to the interface and set up the experiment. [Recommended experiment setting – manual collection, x title: type of solution]
- ③ After starting the experiment, put the pH sensor into the prepared various

solutions, measure and collect the pH value.

- ④ When adding another solution, wash the pH sensor electrode in distilled water and wipe it with tissues carefully.



RESULT

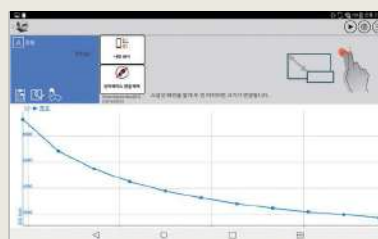

Experiment-Measure pH in Various liquids

PREPARATION

Various liquids, 1 Beaker(250mL), 1 sput, Standard Solution for pH calibration, Kitchen towel, washing glass, 1 pH sensor, 1 MBL interface

SUBJECT

- An acid tastes sour, turns litmus paper red and produces hydrogen gas(H_2) by reacting with metals like iron and zinc.
- A base tastes bitter, turns litmus paper blue and gives slippery feel when touched. Giving no reaction to metals, it produces OH^- ion in water and takes the positive ion from acid.

PROCEDURES

PROCEDURES

- ① Prepare the interface with pH sensor.
- ② Run the Science # (Sciencecube Dedicated Analysis Program) to connect the pH sensor to the interface and set up the experiment. [Recommended experiment setting – manual collection, x title: type of solution]
- ③ After starting the experiment, put the pH sensor into the prepared various solutions, measure and collect the pH value.
- ④ When adding another solution, wash the pH sensor electrode in distilled water and wipe it with tissues carefully.



RESULT



KDS-1041

Video Capture Camera



- Interface : USB 1.1/2.0 compliance
- Resolution : 1.3 Mpixel 1280×908 Via Software Interpolation
- Color : 24bit True Color (24RGB, 1420)
- Sensor : Advanced CMOS Image Sensor
- Turnable Angle : 360 degrees

The Video Capture Camera can be used to record the movement of objects. Also you can analyze the data with the program Video Contents Analyzer which is ScienceCube® supplies.

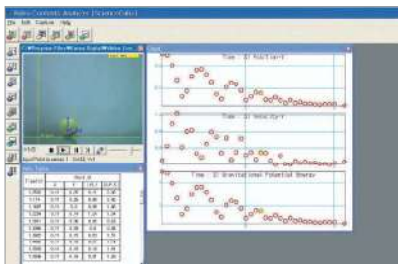

Application Software

Experiment Equipment

Intelligent Timer

KDS-1057

Radiation Monitor II



- Range : 0mR/hr ~ 20mR/hr (0CPM ~ 20,000CPM)
- Resolution : 1CPM
- Temperature Range : 0°C ~ 50°C

The Radiation Monitor II is used to monitor α (alpha), β (beta), and γ (gamma) radiation. It can be used with a number of interfaces to measure the total number of counts per specified timing interval. Since it has its own analog display, it can also be used independent of interfaces in the field to measure radiation levels. The Radiation Monitor II allows to detect the presence of a source of radiation, or to monitor variation in background radiation at different elevations.

KDS-1051

Stethoscope



You can see your heart beat graph with the Stethoscope.

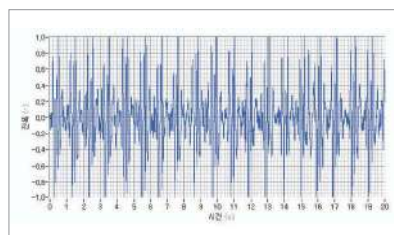

KDS-1017

Turbidity Sensor



- Range : 0NTU ~ 200NTU
- Resolution : 0.25NTU

The Turbidity sensor is designed to measure the turbidity of fresh water or sea water. It's small, simple and easy to use.

The Turbidity Sensor measures turbidity in NTU (the standard unit used by most water collection agencies and organizations). Calibration can be done in about one minute. Also included is a high-grade glass cuvette for the water sample to be measured.

KDS-1031

Pt Stainless Steel Temperature Probe



- Range : -50°C ~ +180°C
- Resolution : 0.06°C
- Probe Properties : **Pt Temperature element (RTD)** Stainless Steel covered.
- Reading speed : 10s(90%)
- Chemical Resistance : 15 minutes (1M HCl)

The platinum temperature probe enables various temperature-related experiments between temperatures -50°C and +180°C At the tip of the probe from which the temperature is measured, there is an element which changes the resistance according to the temperature. The difference of resistance gauged by this element is then converted to a value from the temperature scale. The platinum temperature probe is stainless steel, compatible with most liquids, including water. This probe endures up to 15 minutes in 1M of HCl.

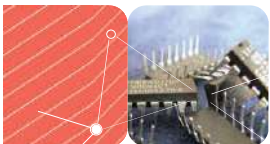

MBL Sensor

KDS-1002W

Thermocouple Probe (Wire type)



- Range : $-200^{\circ}\text{C} \sim 1,200^{\circ}\text{C}$
- Resolution : 0.6°C
- Sensor properties : Type K Thermocouple (wire type)
- Linearity : $0^{\circ}\text{C} \sim 400^{\circ}\text{C} (\pm 3^{\circ}\text{C})$
 $-200^{\circ}\text{C} \sim 0^{\circ}\text{C} (\pm 2^{\circ}\text{C})$

KDS-1001

Stainless Steel Temperature Probe



- Range : $-25^{\circ}\text{C} \sim +125^{\circ}\text{C}$
- Resolution : 0.1°C
- Probe Properties :
Thermistor,
Stainless Steel covered
- Reading speed : 10s (90%)
- Chemical Resistance : 15minutes (1M HCl)

KDS-1002

Thermocouple Probe



- Range : $-200^{\circ}\text{C} \sim +1200^{\circ}\text{C}$
- Resolution : 0.6°C
- Sensor properties :
Type K Thermocouple
Stainless steel covered
- Linearity : $0^{\circ}\text{C} \sim 400^{\circ}\text{C} (\pm 3^{\circ}\text{C})$,
 $-200^{\circ}\text{C} \sim 0^{\circ}\text{C} (\pm 2^{\circ}\text{C})$
- Chemical Resistance : 15minutes (1M HCl)

The Thermocouple Probe is designed to do experiments which need wider range as like measuring flame temperature or dry ice. It responds with high-speed and has long life time.

EXPERIMENT-TEMPERATURE SENSOR

The boiling point of water

PREPARATION

1 Hot plate(or an alcohol lamp), 1 beaker 500mL, Distilled water 500mL, Salt, Boiling Chips, 1 Computer, 1 MBL Interface, 2 temperature Sensors

20HZ, experiment time 10 minutes]Fill the beaker with 400 ml of water, put it on a hot plate and boil the water.

SUBJECT

- Observe changes that occur during heating water and draw a heating curve.
- Explain the water's heating curve and study it.

- Let's find out the difference of boiling point when the water contains other materials as Sugar, Salt, CaCl_2 .

PROCEDURES

Run Science # (Science-cube Dedicated Analysis Program) to connect the temperature sensor to the interface and set up the experiment. [Recommended experiment setting – data collection interval



THE RESULT CHARTS

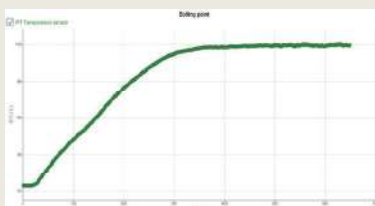

The result curve for boiling point

KDS-1078

Charge Sensor



- Ranges : $\pm 0.5 \text{ V} (\pm 5 \text{ nC})$
 $\pm 2 \text{ V} (\pm 20 \text{ nC})$
 $\pm 10 \text{ V} (\pm 100 \text{ nC})$
- Maximum input : $\pm 150 \text{ V}$
- Typical bias input current : 0.005 pA
- Instrument time constant : 0.1s
- Operation Humidity :
 $0 \sim 95\% \text{ RH, non condens}$
- Operation Temperature Range : $0 \sim 50^{\circ}\text{C}$

KDS-1050

Sensor Adaptor



- Range : 0 ~ 5V
- Resolution : 0,0012 V
- Power : 3 mA

KDS-1049

Spirometer



- Typical Range : -5 ~ +5 L/S
- Max. Range : -10 ~ +10 L/S

KDS-1058

Electric Field Meter



- Range : 1 ~ 1,999V/m
- Sensor Type : Plate Type
- Output type : V-RMS
- Accuracy : ± 1 [dB] of Reading
- Operating Temperature : $-10^{\circ}\text{C} \sim 70^{\circ}\text{C}$
- Sampling Time : 0.2s
- Frequency Range : 15Hz ~ 2kHz

KDS-1026

Digital Control Unit



Specification

- The number of contact point : 3ea (independent)
- Tolerance : AC less than 250V - 5A, DC less than 30V - 5A (per each contact point)
- Life time of contact point : 50 thousand times (less than 20 times per minute within rating)
- Response time : more than 10 mS
- Operating Temperature : 0 ~ 60 °C
- Operating Humidity : 5 ~ 85% R.H.

Spirometer can be used to perform a variety of tests related to air flow and lung volume. The mouthpiece and sensor are designed for safely and accurately measuring both airflow out (expiration) and airflow in (inspiration).

Electric Field Meter measures Electric Field element generating from various electric appliances in the range 15Hz ~ 2kHz. It can measure ELF (Extremely Low Frequency), and it guarantees reliability to 15Hz. It supplies accurate value by using V-RMS output.

KDS-1080

Dissolved CO2 Sensor in water



- Range : 1×10 to 10 M (4,4~400 ppm as CO₂)
- 12-bit Resolution: 0,5mV
- pH Range : Samples and Standards must be adjusted to between pH 4.0 to 4.5
- Temperature Range: 0 to 50 C
- Electrode Resistance : Less than 1000 M Ω
- Reproducibility : $\pm 2\%$

KDS-1059

Magnetic Field Meter



- Range : 0.1mG ~ 199,9mG
1mG ~ 1999mG (Auto Range)
- Sensor Type : pick up coil
- Output Type : V-RMS
- Accuracy : ± 1 [dB] of Reading
- Operating Temperature : $-10^{\circ}\text{C} \sim 70^{\circ}\text{C}$
- Sampling Time : 0.2s
- Frequency Range : 30Hz ~ 2kHz

Magnetic Field Meter measures Magnetic field element generating from various electric appliances in the range 30Hz ~ 2kHz.



MBL Sensor

KDS-1068

Oscilloscope Probe



- Range : -100V ~ +100V, -10V ~ +10V
- Sampling Rate : 40 K S/s

This Oscilloscope Probe is designed to be connected to ScienceCube's data logger for electrical experiment as like voltage, phase difference, period, frequency etc.

KDS-1021

O₂ Gas sensor (0~100%)



- Range : 0 ~ 100 %
- Resolution : 0,03%
- Accuracy (Whichever is greater) : FS ± 1,0% or (Reading ± 1,0%)
- Power : 15 mA

KDS-1045

Blood Pressure Sensor



- Unit : mmHg
- Range : 0 ~ 250 mmHg
- Resolution : 0,0685 mmHg

KDS-1072

Drop Counter



- Rising Time : < 2,5uS
- Falling Time : < 3,8 uS
- Power Requirements : 5VDC, 20mA

KDS-1075

Sound Level sensor



- Unit : dBA
- Range : 40~11dBA
- Resolution (12-bit) : 0,12 dB
- Accuracy (at 94dBA, 23 ° C ± 5 ° C): ± 3 dB

Weather/ Anemometer Sensor

KDS-1076



- Response Time : 200ms
- Operating Temperature : 0°C to 50°C
- Fan size : 75mm Dia * 152mm H
- Cable length: 50cm (can extends 1.5m)

	Range	Resolution	Accuracy
Airflow	0,4 ~ 35m/sec (80 ~ 6900ftm)		±2% full scale
Temperature	- 40°C ~ +125°C	0,25°C	±0,25°C(Typical) ±,1°C(Maximum)
Relative humidity	0 to 100% RH, non-condensing	0,4%RH	±2% from 20% to 80% (@25°C)
Barometric pressure	300 ~ 1100hPa	0,01hPa	± 1,0 hPa (Typical), ±3,0hPa(Maximum)

Experiment List for MBL Sensor

CODE	MBL Sensor	Experiment List
KDS-1001	Stainless Steel Temperature Probe	Boiling Point Freezing Point Temperature Change with Water Level Water Temperature Change by Electric Current Chemical Reaction & Thermal Energy Crystal Observation Experiment
KDS-1002	Thermocouple Probe	Temperature Measurement from various materials (Liquid nitrogen, Dry ice, Soybean oil, etc.) Combustion Flames Measurement, (Flame temperature, etc.) Research of condition change on materials
KDS-1002W	Thermocouple Probe (Wire type)	Experiment on the change of Bunsen burner inner flame temperature by different location Comparative experiment with other flame temperature Measurement on a melting point
KDS-1005	pH Sensor	pH Measurement Acidity Measurement according to liquid Acid Rain
KDS-1007	Magnetic Field Sensor	Fleming Law Lorentz Law Magnetic Field Change by Distance Magnetic Field Change by Surrounding Objects Magnetic Force Measurement Experiment from Solenoid and Helmholtz Coil Magnetic Field Experiment on Growth and Activity of Various Organisms Physical Motion Experiment (Cycle, Velocity Detection) by Strobo Timing
KDS-1008	Relative Humidity Sensor	Increase Production Rate by Relative Humidity Observation with Plants in Sealed Room When to Observe the Optimum Growth Condition in Greenhouse or Terrarium To check Frequent Electrostatic Occurrence Day
KDS-1009	Different Voltage Probe	Ohms Law Brightness Connection of Lights between Voltage and Bulb Voltage Measurement of Volta Battery Coil Experiment Fruit Battery Experiment Electric Energy Series and Parallel Circuit Experiment
KDS-1010	Current Probe	Coil Experiment Ohm's Law Electric Energy Circuit Experiment on both Series and Parallel
KDS-1012	Microphone	Research on a wavy pattern of voice according to a pitch and amplitude Comparison on a wavy pattern of instrument Comparison on a wavy pattern of tuning fork Sound Speed Measurement from reflection of sound in tube Decision on cycle or pitch of sound by analyzing a sound wavy pattern Analysis by high FFT
KDS-1013	Sound Level Meter	Research about Noise block of Street Sound Measurement in Classroom Comparisons from Noise Units
KDS-1014	Accelerometer 5G	Acceleration Measurement in elevator Gravity Acceleration Measurement of the Earth Newton's Second Law Verification Acceleration Measurement effect on cart or certain material Spin Acceleration Measurement on spinning material Acceleration Measurement while bungee jumping
KDS-1016	Barometer	Change of air pressure during a day
KDS-1017	Turbidity Sensor	Turbidity Measurement for the lower and upper reaches of a river Turbidity change for sunny day and after rainy day
KDS-1020	CO ₂ Gas Sensor	Carbon Dioxide Amount Measurement in Classroom Carbon Dioxide Change Observation during Photosynthesis of Plant Carbon Dioxide Change Observation during Cellular Respiration of Plant Carbon Dioxide Amount Measurement by Chemical Reaction with Hydrochloric Acid and Sodium Hydrogen Carbonate Increase rate of Carbon Dioxide Amount by Small Organisms like Insects or Bugs
KDS-1022	Dissolved Oxygen Probe	Comparisons of Dissolved Oxygen Amount on Drinking Waters Reduction Change Measurement of Oxygen Amount in Breathing

CODE	MBL Sensor	Experiment List
KDS-1023	Photogate	Speed & Acceleration Measurement with Straight-line Motion Object Cycle Measurement of Simple Pendulum Motion Calculation of Velocity, Acceleration, and more by measuring time intervals of moving objects among Photogates and connect by Daisy-Chain method with several photogates Gravity Acceleration Measurement from Motion of Free-Fall Movement Observation of Stopped Object Act on Drop Coefficient of Neutralization Titration by utilizing Event Experiment
KDS-1029	Dual Range Force Sensor II	Friction Simple Harmonic Motion Experiment of Force and Impact with collision Centripetal Force Hooke's Law Newton's Second Law Force Measurement for pick up objects by using a simple device
KDS-1031	Pt Stainless Steel Temperature Probe	Boiling Points from various materials Freezing Points from various materials Temperature Change with Water Level Water Temperature Change by Electric Current Chemical Reaction & Thermal Energy Crystal Observation Experiment
KDS-1032	Gas Pressure Sensor B	Yeast Breath Transpiration Gas Reaction
KDS-1033	Photometric Light Sensor	Relation between Voltage and Brightness of Light Light Role for Photosynthesis (by different levels of Light Intensity) and Transpiration Weather Research by Sunrise, Sunset Measurement Light Intensity from Distance Polarized Filter Experiment
KDS-1034	Gas Pressure Sensor A	Boyle's Law Charles Law Breath Velocity Measurement of Germinated Bean Pattern Research of Human Breath by Using Breath Analyzer
KDS-1035	Galvanometer	Making Battery (Coin Battery, Fruit Battery) Electrolyte and Ions (Current Flowing Object) Current Reaction (Electricity)
KDS-1037	High Concentration CO ₂ Sensor	Carbon Dioxide Amount Measurement of chemical reaction or combustion experiment Density change of carbon dioxide according to human respiration
KDS-1038	Conductivity probe	Conductivity Measurement on Different Concentrations of Electrolyte Solutions Conductivity Measurement on Surrounding Solutions like Acid Rain, Polluted Water
KDS-1039	ORP Sensor	Comparison on Oxidation-Reduction of Surrounded Environment like in Rainwater, Stream, Lake, etc. Optimal Potential Difference Comparison for the Oxidation-Reduction on Drinking Water Equilibrium Point Finding
KDS-1040	EKG Set	P, Q, R, S, T Wave Research Heartbeat Measurement after Exercise Heartbeat Check on Various Poses Abnormal Diagnosis of Coronary Sickness (Angina, Myocardial Infarction), Arrhythmia, Electrolyte
KDS-1041	Video Capture Camera	Motion Measurement of material and Research on exercise condition
KDS-1042	Motion Sensor II	Pendulum Movement Motion of Free Fall Distance Measurement from Straight-line Motion Object Movement of Cart on Track Simple Harmonic Oscillator on Spring as like Pendulum Motion of Bounce Ball
KDS-1044	Colorimeter II	Beer-Lambert law Measurement for concentration of an unknown solution Photosynthetic experiment
KDS-1045	Blood Pressure sensor	Maximum and minimum of blood pressure, and heart beat Measurement Contraction Measurement and relaxation of pressure Relation with heart beat and pressure signal Measure blood pressure change and heart rate change Influence on pressure by the process of digestion compare pressure with smoker and non-smoker
KDS-1046	Heart Rate Monitor	Comparative experiment on heart rate among people. Heart rate Measurement during, after, and before exercise Time Measurement to recover heart rate after exercise Heart rate Measurement after or before eat (Coke or coffee)

CODE	MBL Sensor	Experiment List
KDS-1047	Oxygen Gas Sensor II	Oxygen Amount Measurement in Classroom Oxygen Amount Change Observation during Photosynthesis of Plant Oxygen Reduction Measurement in Small organisms like Insects, Bugs Oxygen Amount occurrence Measurement during Hydrogen Peroxide decomposition by Catalase Oxidation Measurement of metal and Iron
KDS-1048	Accelerometer 25G	Acceleration Measurement from collision Relation Research of Acceleration rate on acceleration measurement, cycle, radius and mass, etc, of horizontal spinning material. Acceleration Measurement of vertical spinning material Acceleration Measurement Research from knee bending and stretching during jump after connecting accelerometer sensor to human body.
KDS-1049	Spirometer	Breathing condition on positions Relations of airflow and capacity of lung Breathe Comparisons according to exercise in different condition
KDS-1051	Stethoscope	Comparisons on heart rate between human and animal, Comparisons on heart rate between stability and exercise condition.
KDS-1053	Balance 1	Mass measurement of Object
KDS-1054	Balance 2	Mass measurement of Object
KDS-1055	Salinity Sensor	Salinity Comparison from Freshwater to Sea Water Salinity Measurement on Salt Water Salinity Comparisons on Drinking Water, Beverages Salinity Comparisons on Surrounded Environment Water like Rain, River, etc.
KDS-1056	Respiration Monitor	Breath Comparisons before and after exercise Breath Comparisons with positions
KDS-1057	Radiation Monitor II	Radiation Measurement Half-life Measurement Intensity Measurement on Blackout Curtain Types
KDS-1059	Magnetic Field Meter	Magnetic field comparisons occurred from various electronics
KDS-1061	Absolute Pressure Sensor Ion Selective Electrode	Measurement of chemical reaction rate Ideal gas equation (Boyle's law, Charle's law) Research of Steam pressure according to temperature Measurement hard water (calcium ion): check amount of mineral on sample of fresh water
KDS-1063	Magnetic Field Sensor II	Magnetic field Comparisons by the number of times for a winded coil N-pole and S-pole finding Magnetic field by current Helmholtz Coil magnetic field Magnetic field Comparisons with distance
KDS-1064	Calcium Ise Probe	Measurement nitrate: sample of sewage or manure
KDS-1065	Ammonium Ise Probe	Measurement salinity and chloride of sea: measurement chloride concentration and salinity of sample of sea.
KDS-1066	Nitrate Ise Probe	Measurement ammonium: when water flows from manure of soil
KDS-1067	Chloride Ise Probe	Measurement milk in calcium: after skim off the film of the top, measure calcium in milk,
KDS-1068	Oscilloscope Probe	
KDS-1069	Heart Rate Monitor(hand-grip type)	Comparative experiment on heart rate among friends Comparison heart rate after or before exercise Comparison heart rate after eat
KDS-1070	Heart Rate Monitor (Ear-clip type)	Comparative experiment on heart rate among friends Comparison heart rate after or before exercise Comparison heart rate after eat
KDS-1071	Rotary Motion Sensor	Pendulum motion Rotary motion Angular speed measurement
KDS-1072	Drop Counter	Acid-base Experiment Electrical conductivity Experiment
KDS-1073	Rotary Motion (Digital Type)	Moment of inertia Torque
KDS-1076	Weather Sensor	Making power curve of Small wind turbine Solar hybrid system efficiency Comparisons from AC generator with wind generator turbine
KDS-1077	UV Sensor	UV Comparison with plastic and glass UV Comparison with sunny and rainy day UV Comparison with sunblock and effect
KDS-1078	Charge Sensor	Charging Measurement by friction, touch, motivation Electricity Measurement of (+) and (-) Faraday experiment

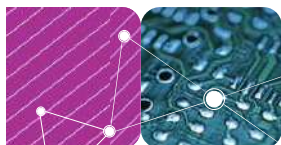

Quick USB Sensor

No Need additional Data Loggers!



Sensor

Computer Program

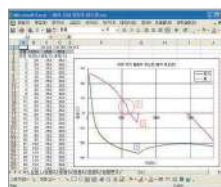

Draw an interactive graph along with data collection

Just plug Quick Sensor Series to your computer USB port!!

ScienceCube supplies USB connect sensors which can connect interface, directly.

No needs to connect interface, directly operates ScienceCube's software. USB Sensor Series can be easily used to record all sort of experiment circumstance.

QUSB-1001

Quick USB Temperature Sensor



- Range : $-25^{\circ}\text{C} \sim +125^{\circ}\text{C}$
- Resolution : 0.1°C
- Probe Properties : Thermistor, Stainless steel covered
- Reading speed : 10s (90%)
- Chemical Resistance : 15 minutes (1M HCl)

QUSB-1007

Quick USB Magnetic Field Sensor



- Range : $-50 \sim +50 \text{ G}$
- Resolution : 0.024 G

QUSB-1009

Quick USB Differential Voltage Probe



- Input Voltage Range : $-12.0\text{V} \sim +12.0\text{V}$
- Resolution : 3.1mV

QUSB-1005

Quick USB pH Sensor



- Range : pH 0 ~ pH 14
- Resolution : 0.0036 pH units

QUSB-1008

Quick USB Humidity Sensor



- Range : 0% ~ 100%
- Resolution : 0.1%

QUSB-1010

Quick USB Current Probe



- Range : DC $-1.2\text{A} \sim +1.2\text{A}$
- Resolution : 0.6mA

QUSB-1013

Quick USB Sound Level Sensor



- Range : 40dB ~ 110dB
- Accuracy : 1.5dB

QUSB-1029

Quick USB Force Sensor



- Range : $-10\text{N} \sim +10\text{N}$ / $-80\text{N} \sim +80\text{N}$
- Resolution : 0.0056 / 0.056
- Sensor Type : Electrical Strain Gauge

Force Sensor II is measuring force in the range of $\pm 10\text{N}$ or $\pm 80\text{N}$.

It is used to measure the change of force quantity comprehensively.

QUSB-1033

Quick USB Light Sensor



- Full Range : 0 lx ~ 15,000 lx
- General Range : 0 lx ~ 6000 lx
- Sensitive Range : 0 lx ~ 600 lx
- Spectral Response Range : $3300 \text{ \AA} (330\text{nm}) \sim 7200 \text{ \AA} (720\text{nm})$

QUSB-1023

Quick USB Photogate Interface



INTERNAL GATE

- Infrared source peak wavelength : 880nm
- Rising Time : $2.5 \mu\text{s}$
- Falling Time : $3.8 \mu\text{s}$

EXTERNAL GATE

- Infrared source peak wavelength : 880nm
- Spectrum Sensitivity : 500nm~1050nm
- Rising Time : $8 \mu\text{s}$
- Falling Time : $10 \mu\text{s}$



QUSB-1034

Quick USB Gas pressure Sensor [A]



- Range : $-1,000\text{hPa} \sim 3,000\text{hPa}$
- Resolution : 1.3hPa

The Differential Gas Pressure Sensor A is suitable for measuring minute change of pressure.

QUSB-1042

Quick USB Motion Sensor



- Range : 0.15m ~ 6m (Max. 10m)
- Resolution : 1 mm
- Gauging principle : Ultra sonic transducer
- Beam angle : Cone, around 15°
- Sampling rate : (Max. 100 samples/s)
- Depends on measuring distance

The Motion Sensor is designed to detect object position by Ultra Sonic wave. You can do variety experiment with Motion Sensor such as pendulum movement, free falling movement etc.

QUSB-1047

Quick USB Oxygen Gas Sensor



- Range : 0% ~ 27%
- Resolution : 0.01 %

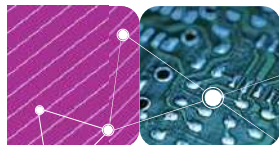

Quick USB Sensor

QUSB-1048

Quick USB Accelerometer 25g



- Full range : $-245\text{m/s}^2 \sim +245\text{m/s}^2$
- Available range : $-98\text{m/s}^2 \sim +98\text{m/s}^2$
- Resolution : 0.2m/s^2
- Frequency Response : $0\text{Hz} \sim 100\text{Hz}$

Accelerometer 25g probe can be used for a wide variety of experiments both indoor and outdoor. It measures acceleration along the line marked by the arrow on the sensor.

QUSB-1039

Quick USB ORP Sensor



ORP Electrode

- Type : Sealed, gel-filled, epoxy body, Ag (AgCl) reference
- Storage solution : pH4 KCl solution
- Temperature range : $0^\circ\text{C} \sim 60^\circ\text{C}$
- Impedance : $\sim 20\text{M } \Omega$ at 25°C

Electrode(ORP) Amplifier

- Amplifier input range : $-450\text{mV} \sim 1,100\text{mV}$
- Resolution : 0.5mV

QUSB-1016

Quick USB Barometer



- Range : $0\text{hPa} \sim 2,068\text{hPa}$
- Resolution : 0.63hPa

QUSB-1014

Quick USB Accelerometer 5g



- Full range : $-47\text{m/s}^2 \sim +47\text{m/s}^2$
- Available range : $-19.6\text{m/s}^2 \sim +19.6\text{m/s}^2$
- Resolution : 0.038m/s^2
- Frequency Response : $0\text{Hz} \sim 100\text{Hz}$

QUSB-1017

Quick USB Turbidity



- Range : $0\text{NTU} \sim 200\text{NTU}$
- Resolution : 0.25NTU

Turbidity is a measure of water's lack of clarity and is an important indicator of water quality. Water with high turbidity is cloudy, while water with low turbidity is clear.

QUSB-1054

Quick USB Balance (500g)



- Range : $0\text{g} \sim 500\text{g}$
- Resolution : 0.1g

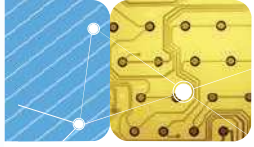

Lap Equipment

SCS-300

Photosynthesis Experimental Equipment

✓ Possible Experiment List

- Respiration of plant
- Photosynthesis of plant
- Photosynthesis by an intensity of light
- Photosynthesis with CO₂
- Photosynthesis and Transpiration
- Sensor is not included

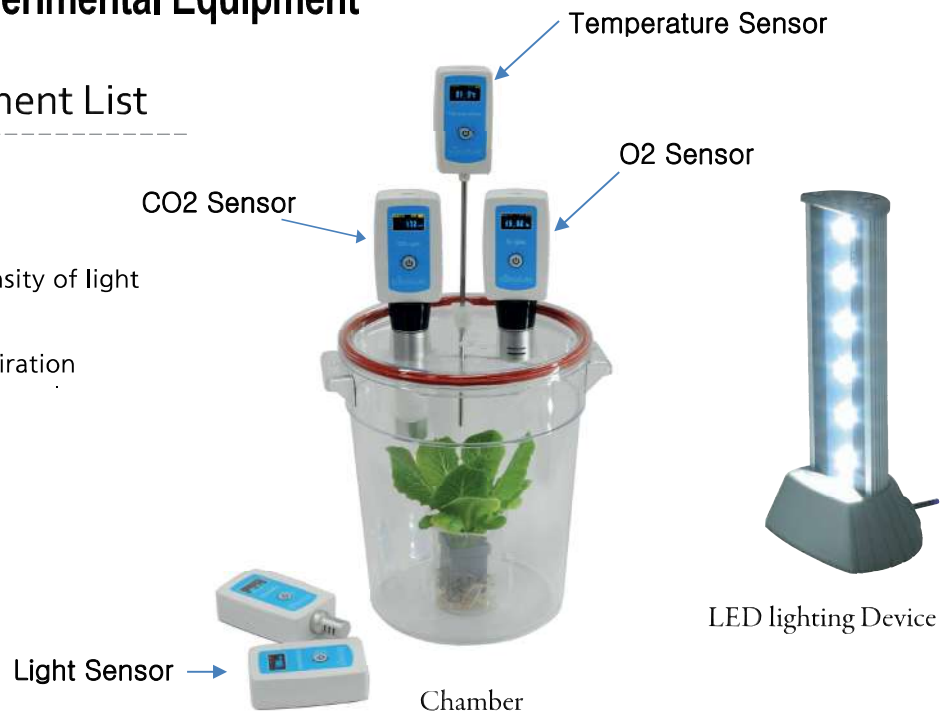

Strong Points!

1. NO need to purchase submerged plant!

As from water plants, it is impossible to count numbers of dissolved O₂ bubble from land plant.

The existing experiment may even derive to errors of simple comparison.

With the photosynthesis experiment device, any types of leaves like lettuce are measurable.

This benefits feasible experiment anywhere at any time.



2. NO need to have water tank by using LED!

Chamber is designed to block air leakage and special LED dimmer for rising internal Chamber temp. from light and heat is used.

This includes blackout curtain of light for respiratory experiment.

3. Various physical quantity at the same time, YES! Real-time observation, YES!

Temperature, CO₂, Humidity, Photodiode, and etc. can be observed simultaneously with changing graphs in real-time.

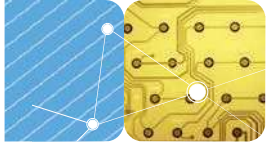

Lap Equipment

SCS-500

Multi-Functional Dynamics System

Low Friction, Diverse Accessories,
Various Application

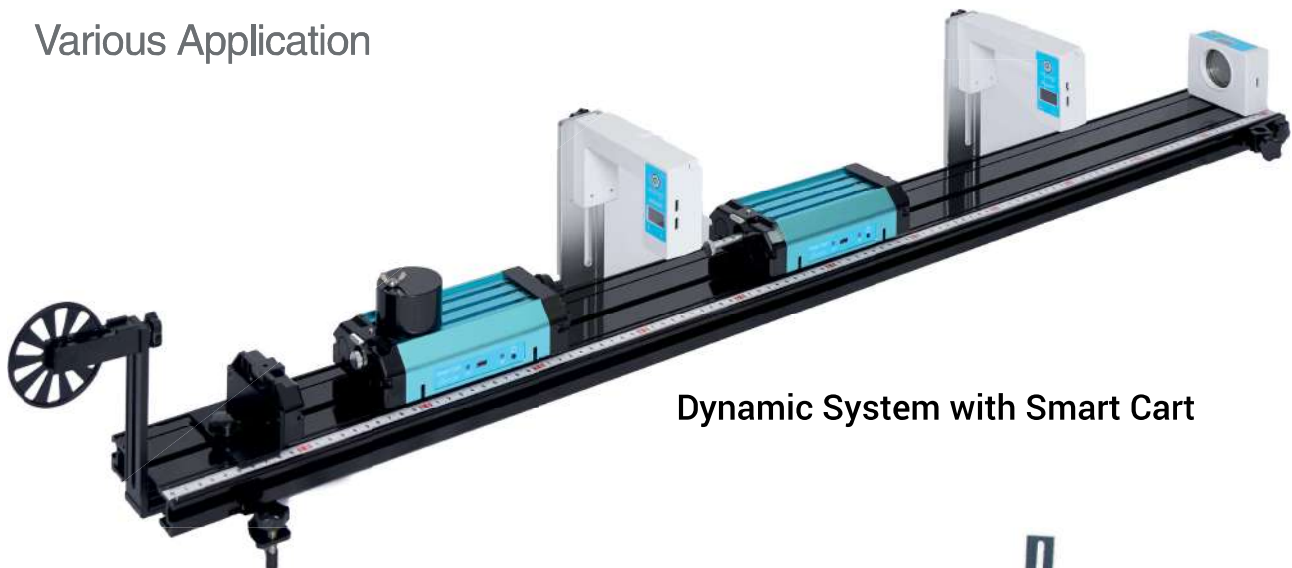

Dynamic System with Smart Cart



Accessories

The Multi-Functional consists of a 1.2m track, two carts, and related accessories. The system is designed for use in physics and physical scientific experiments. Dynamics system enables more accurate and precise experiment by minimizing friction. Sensors like Motion sensor, Force sensor, Photogate, Accelerometer etc. can be adopted to measure exact data.

Some typical experiments done with the system and include

- Newton's law
- Conservation of Energy
- Uniform Motion
- Spring Constant
- Motion under constant acceleration
- Inelastic collisions and elastic collision

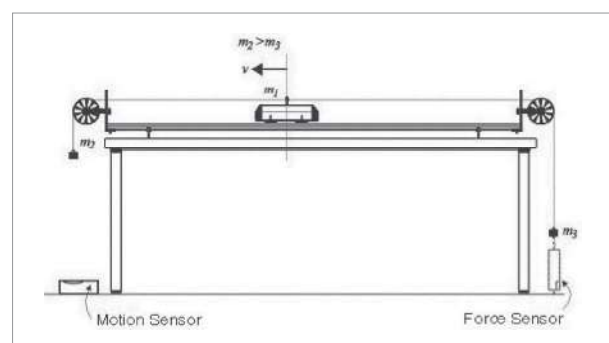

Determination of mass on an incline

Gate Timer Package

Gate Timer Package detects a period of reciprocation. This package shows the period directly without interface or computer. The photogate in this package adopts magnets so it can be attached on blackboards or rods.

✓ COMPOSITION

- Gate Timer
- 2 Photogates
- Sensor cable
- Manual



Air Track system



Usable Length : 1.5m
 Linearity : error $\leq 0.1\text{mm}$ in full length
 Slipper float weight : 3 times of slipper weight
 Slipper float height : $\geq 0.1\text{mm}$

The Air Cushion Track is specially designed for precise motion experiment by reduction of frictional resistance. You can investigate various motion's law as uniform motion, average and instantaneous velocities, uniform acceleration, conservation of energy with ScienceCube® Photogate or Motion Detector.



EXPERIMENT WITH PHOTOGATE

The Photogate is good for Measuring Velocity and investigating conservation of energy with Air Track.



EXPERIMENT WITH MOTION DETECTOR

The Motion detector is suitable for bi-directional measurements of motion with the Air Track.



Lap Equipment

SCS-700

Gas Volume Package

1. Description

Gas volume Package (SCS-700) is designed to register gas temperature and measure gas volume. This package has to be connected to Data Logger and computer. Gas Volume Package can be used in elementary, middle, high school and also general physical, chemical laboratories.

2. Specification

- Range: 0ml (350ml) ~ 400ml (850ml)
- Error: under 63%
- Gas Temperature Range: 0°C ~ +80°C
- Error on measuring temperature : under 62%
- Dimension : length - 410 mm
width - 90 mm
height - 100 mm
- Length of cable : 120 mm
- Weight : 300gr



SCS-800

Boyle's Law Package

1. Description

Boyle's Law Package (SCS-800) is designed to explore the elastic properties and volume / pressure relationship how the pressure of a gas tends to decrease as the volume of a gas increases. This package has to be connected to Data Logger and computer for the experiment. Boyle's Law Package can be used in elementary, middle, high school and also general physical, chemical laboratories.

2. Composition

Dimension: 180 X 130 X 170 (mm)

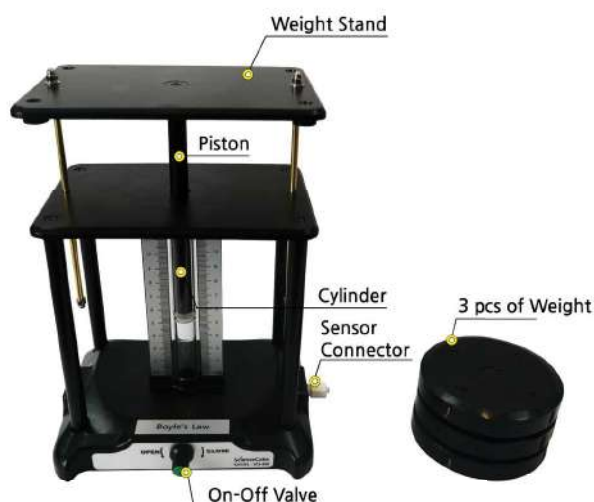

Vacuumed Chamber

It is an experimental device that can measure changes in pressure and temperature in the process of creating a vacuum inside the chamber by connecting with the MBL sensor.

Components

- Chamber(1000ml) and pump
- Valve socket for temp and pressure sensor
- Manual



■ MBL Products Package List

We set package basically. Surely, You could customize for your need.

Code	Name	Subject				Level			
		PHYSICS	CHEMISTRY	BIOLOGY	EARTH SCIENCE	ELEMENTARY	MLDDLE	HIGH	UNIVERSITY
KDM-BLU01	Free Linker	★Optional	★Optional	★Optional	★Optional	★Optional	★Optional	★Optional	★Optional
KDS-MAX Vb	MAX Vb	★Optional	★Optional	★Optional	★Optional	★Optional	★Optional	★Optional	★Optional
KDS-ADVANCE II	MAX Advance II	★Optional	★Optional	★Optional	★Optional	★Optional	★Optional	★Optional	★Optional
KDM-1001	Lite II	★Optional	★Optional	★Optional	★Optional	★Optional	★Optional	★Optional	★Optional
KDM-1002	Pro	★Optional	★Optional	★Optional	★Optional	★Optional	★Optional	★Optional	★Optional
KDS-1001	Stainless Steel Temperature Sensor	★	★	★	★	★	★	★	★
KDS-1002	Thermocouple Sensor	★	★	★	★	★	★	★	★
KDS-1002W	Themocouple Sensor [Wire type]	★	★	★	★	★	★	★	★
KDS-1005	pH Sensor	★	★	★	★	★	★	★	★
KDS-1007	Magnetic Field Sensor	★	★	★	★	★	★	★	★
KDS-1008	Relative Humidity Sensor	★	★	★	★	★	★	★	★
KDS-1009	Differential Voltage Sensor	★	★	★	★	★	★	★	★
KDS-1010	Current Sensor	★	★	★	★	★	★	★	★
KDS-1012	Microphone	★	★	★	★	★	★	★	★
KDS-1013	Sound Level Meter	★	★	★	★	★	★	★	★
KDS-1014	Accelerometer 5G	★	★	★	★	★	★	★	★
KDS-1016	Barometer	★	★	★	★	★	★	★	★
KDS-1017	Turbidity Sensor	★	★	★	★	★	★	★	★
KDS-1020	CO ₂ Gas Sensor	★	★	★	★	★	★	★	★
KDS-1021	O ₂ Gas sensor (0~100%)	★	★	★	★	★	★	★	★
KDS-1022	Dissolved Oxygen Probe	★	★	★	★	★	★	★	★
KDS-1023	Photogate	★	★	★	★	★	★	★	★
KDS-1029	Dual Range Force Sensor II	★	★	★	★	★	★	★	★
KDS-1031	PT Stainless Steel Temperature Sensor	★	★	★	★	★	★	★	★
KDS-1032	Gas Pressure Sensor B	★	★	★	★	★	★	★	★
KDS-1033	Photometric Photodiode Light Sensor	★	★	★	★	★	★	★	★
KDS-1034	Gas Pressure Sensor A	★	★	★	★	★	★	★	★
KDS-1035	Galvanometer	★	★	★	★	★	★	★	★
KDS-1037	High Concentration CO ₂ Gas Sensor	★	★	★	★	★	★	★	★
KDS-1038	Conductivity Sensor	★	★	★	★	★	★	★	★
KDS-1039	ORP Sensor	★	★	★	★	★	★	★	★
KDS-1040	EKG [ECG] Set	★	★	★	★	★	★	★	★
KDS-1041	Video Capture Camera	★	★	★	★	★	★	★	★
KDS-1042	Motion Sensor II	★	★	★	★	★	★	★	★
KDS-1043	Ion Selective Electrode Amplifier	★	★	★	★	★	★	★	★
KDS-1044	Colorimeter II	★	★	★	★	★	★	★	★
KDS-1045	Blood Pressure Sensor	★	★	★	★	★	★	★	★
KDS-1046	Heart Rate Monitor (Chest Belt)	★	★	★	★	★	★	★	★
KDS-1047	Oxygen Gas Sensor II (0~27%)	★	★	★	★	★	★	★	★
KDS-1048	Accelerometer 25G	★	★	★	★	★	★	★	★
KDS-1049	Spirometer	★	★	★	★	★	★	★	★
KDS-1051	Stethoscope	★	★	★	★	★	★	★	★
KDS-1053	Balance I (200g/0,01g)	★	★	★	★	★	★	★	★
KDS-1054	Balance II (500g/0,1g)	★	★	★	★	★	★	★	★
KDS-1055	Salinity Sensor	★	★	★	★	★	★	★	★
KDS-1056	Respiration Monitor	★	★	★	★	★	★	★	★
KDS-1057	Radiation Monitor II	★	★	★	★	★	★	★	★
KDS-1061	Absolute Pressure Sensor	★	★	★	★	★	★	★	★
KDS-1063	Magnetic Field Sensor II [with Scale]	★	★	★	★	★	★	★	★
KDS-1064	Ion Selective Electrode Calcium ISE Probe	★	★	★	★	★	★	★	★
KDS-1065	Ion Selective Electrode Ammonium ISE Probe	★	★	★	★	★	★	★	★
KDS-1066	Ion Selective Electrode Nitrate ISE Probe	★	★	★	★	★	★	★	★
KDS-1067	Ion Selective Electrode Chloride ISE Probe	★	★	★	★	★	★	★	★
KDS-1068	Oscilloscope Probe	★	★	★	★	★	★	★	★
KDS-1069	Heart Rate Monitor [Hand-grip type]	★	★	★	★	★	★	★	★
KDS-1070	Heart Rate Monitor [Ear Clip type]	★	★	★	★	★	★	★	★
KDS-1071	Rotary Motion Sensor [Analog]	★	★	★	★	★	★	★	★
KDS-1072	Drop Counter	★	★	★	★	★	★	★	★
KDS-1073	Rotary Motion(Digital Type)	★	★	★	★	★	★	★	★
KDS-1075	Sound Level sensor	★	★	★	★	★	★	★	★
KDS-1076	Weather/Anemometer Sensor	★	★	★	★	★	★	★	★
KDS-1077	UV Sensor	★	★	★	★	★	★	★	★
KDS-1078	Charge Sensor	★	★	★	★	★	★	★	★
KDS-1080	Dissolved CO ₂ Sensor in water	★	★	★	★	★	★	★	★
SCS-200	Neutralization Titration Package	★	★	★	★	★	★	★	★
SCS-300	Photosynthesis Experiment Package	★	★	★	★	★	★	★	★
SCS-500	Multi-functional Dynamics System (1,2m/1,8m)	★	★	★	★	★	★	★	★
SCS-600	Gate Timer Package	★	★	★	★	★	★	★	★
SCS-700	Gas Volume Package	★	★	★	★	★	★	★	★
SCS-800	Boyle's Law Package	★	★	★	★	★	★	★	★
SCS-900	2 Channel USB Oscilloscope	★	★	★	★	★	★	★	★
SCS-1000	Intelligent Timer	★	★	★	★	★	★	★	★
SCS-1200	Rotational Momentum Package	★	★	★	★	★	★	★	★
KDA-12	Square Cuvette	★	★	★	★	★	★	★	★
KDA-15	Pulley	★	★	★	★	★	★	★	★
KDA-16	Cart Picket Fence	★	★	★	★	★	★	★	★
KDA-17	Picket Fence	★	★	★	★	★	★	★	★
KDA-19	CO ₂ -O ₂ tee	★	★	★	★	★	★	★	★



Spreading Science & Technology for a Better World



Head Office - Indore

Nvis Technologies Pvt. Ltd.

141-A, Electronic Complex, Pardesipura, Indore - 452 010, Madhya Pradesh, India.

Mobile: +91 73899 00887, +91 98932 70303, Email: info@nvistech.com

Branch Offices: New Delhi · Pune · Kochi